



Voyantic

Tagsurance 3

Manual

September 9, 2024

1	Overview	6
2	Terminology.....	8
2.1	Visualization of the lanes, stations, and stages.....	10
3	System components.....	11
3.1	Tagsurance controller	11
3.1.1	Server	12
3.1.2	Router	13
3.1.3	PoE switch	14
3.1.4	USB hub.....	14
3.1.5	USB-to-serial adapter	14
3.1.6	Lane controller	15
3.2	Trigger sensor.....	16
3.3	Rotary encoder	16
3.4	Station devices	17
3.4.1	Tagsurance UHF	17
3.4.2	Tagsurance SL UHF	17
3.4.3	Tagsurance HF	18
3.4.4	Marker.....	18
3.4.5	Puncher.....	19
3.4.6	IO-only device.....	19
3.5	IO Breakout.....	19
3.5.1	IO breakout versions compatibility.....	20
3.6	Strobe Light	20
4	Installation	21
4.1	Installing Snoop Pro coupling elements	22
4.1.1	Verifying Snoop Pro installation (verifying RF connections).....	22
4.2	Installing the rotary encoder	25
4.3	Installing the trigger sensor	26
4.3.1	Installing and training SICK contrast sensor.....	26
4.3.2	Installing and training SICK color contrast sensor.....	28
4.4	Installing stations	30
4.4.1	Tagsurance SL UHF	30
4.4.2	Tagsurance UHF	31
4.4.3	Tagsurance HF	31
4.4.4	Marker.....	33
4.4.5	Puncher.....	33
4.4.6	IO-only device.....	34
4.4.7	IO cable for Voyantic devices	36

4.5	Connecting cables	37
4.5.1	Rotary encoder and trigger sensor	37
4.5.2	Stations	37
4.5.3	IO Breakout.....	37
4.5.4	Strobe Light.....	38
4.5.5	Machine IO.....	39
4.5.6	Lane controllers	39
4.5.7	Tagsurance network	39
4.6	Connecting to the Tagsurance system	40
4.6.1	Direct connection	40
4.6.2	Network connection	40
4.6.3	APIs	42
5	Building lane configuration	43
5.1	Lane controller	44
5.1.1	Machine IO.....	45
5.2	Stations.....	46
5.2.1	Distance from trigger	46
5.2.2	Tagsurance UHF 1.x.....	47
5.2.3	Tagsurance HF	47
5.2.4	Tagsurance SL UHF	47
5.2.5	Marker.....	47
5.2.6	Puncher.....	48
5.2.7	IO-only device.....	49
6	Building a recipe	50
6.1	Recipe Builder overview	50
6.1.1	Recipe Builder installation	51
6.2	Add stations	51
6.3	Define task lists for stations	52
6.3.1	Task list for Tagsurance UHF & Tagsurance SL UHF	52
6.3.2	Task list for Tagsurance HF.....	56
6.4	Variables and mapping definitions.....	59
6.5	Example case of recipe building.....	59
7	Running a job	61
7.1	Updating a lane configuration.....	61
7.2	Selecting a recipe	62
7.3	Job configuration	62
7.3.1	Job type selection	62
7.3.2	Trigger settings	66

7.3.3	Lot settings.....	69
7.3.4	Cut mark	71
7.3.5	Action trigger.....	73
7.4	Results	74
7.4.1	Results in operator UI	74
7.4.2	Result saving	76
7.4.3	Result archive	77
7.4.4	Error codes	77
7.5	Metrics in operator UI	79
8	Hardware maintenance.....	81
9	Updating the software	82
9.1	Tagsurance controller	82
9.2	Lane controller firmware	82
9.3	Updating Voyantic stations	82
9.3.1	Tagsurance SL UHF	82
9.3.2	Tagsurance HF	82
9.3.3	Tagsurance UHF	83
10	Technical specifications	84
10.1	Digital IO of lane controller	84
10.1.1	IO cables.....	84
10.1.2	Trigger connector.....	84
10.1.3	Rotary encoder connector	85
10.1.4	Station connector	85
10.1.5	Machine IO connector.....	88
10.1.6	Output signal current limits	90
10.2	Standard Tagsurance 3 device IO port.....	91
10.3	Digital signals of IO Breakout	92
10.4	Station locations	92
10.5	APIs	93
10.5.1	REST API.....	93
10.5.2	AsyncAPI	93
10.6	Tagsurance SL UHF	93
10.6.1	RF performance	93
10.6.2	Protocol parameters	93
11	Appendix: How to Configure the Pattern Trigger	95
11.1	What is the Pattern Trigger.....	95
11.2	How Pattern Trigger Works	96

11.3	Pattern Trigger Configuration	97
11.3.1	Active and Passive Sections.....	97
11.3.2	Trigger Location Offset	98
11.4	Simulated Triggers.....	98
11.4.1	Simulated Trigger with Pattern Trigger	98
11.5	Hold Off Distance.....	100
11.6	Summary of Pattern Trigger Configuration.....	101

1 Overview

The Tagsurance 3 system is a turnkey solution for testing UHF and HF RFID tags in tag production machines. It is optimal but not limited to be used in chip attachment, label converting, and final personalization stages.

Voyantic delivers the Tagsurance 3 system complete with *stations* that conduct the tag testing and encoding. The trigger signal to the system can come either from the machine or from a trigger sensor delivered by Voyantic. Depending on the use case, we strongly recommend to connect the trigger sensor to Tagsurance 3, as trigger filtering features, such as pattern filtering, are then available. Tagsurance 3 comes with its own rotary encoder for location sensing. All IO signals necessary for operating the system are handled within the system itself and do not need interfacing with the machine.

Tagsurance 3 uses its own configuration and *recipe* for a job and then initializes the stations accordingly so that they know what to do when the lane controller triggers them. The lane controller handles the triggering of all stations on the lane when tags travel past. Each station sends its result as data (serial port or Ethernet) to the Tagsurance controller PC and the system then gathers the job results from this data.

Tagsurance 3 is easy to integrate to a production line or machine, as it can work independently and does not necessarily need to interface with the machine or logic controlling the production line.

Tagsurance 3 is simple and quick to configure for the machine. This lane configuration contains information on where and how trigger sensor, Snoop Pro coupling elements, marker and other such stations are installed.

Tagsurance 3 is easy to operate with a browser-based operator UI that acts as a server in your computer connected to Tagsurance 3 and browser pointed to Tagsurance 3's IP address:

- Either via connecting Tagsurance 3 to your internal network from which it receives its IP address via DHCP
- Or as a point-to-point connection to a fixed IP in the system.

As your computer will receive an IP address in the same range via DHCP, in most cases there is no need for changing the settings on it.

Tagsurance 3 also allows machine manufacturers or end users to build their own operator user interface, as the system offers a complete REST API and AsyncAPI which have the same functionality as is used by Tagsurance 3's own operator UI. Voyantic reserves the right for some limitations in special cases.

Tagsurance 3 can interface with the machine via a machine IO that can offer, for example, start and stop signals to the machine that can be connected when you want to control such operations by the Tagsurance 3 system.

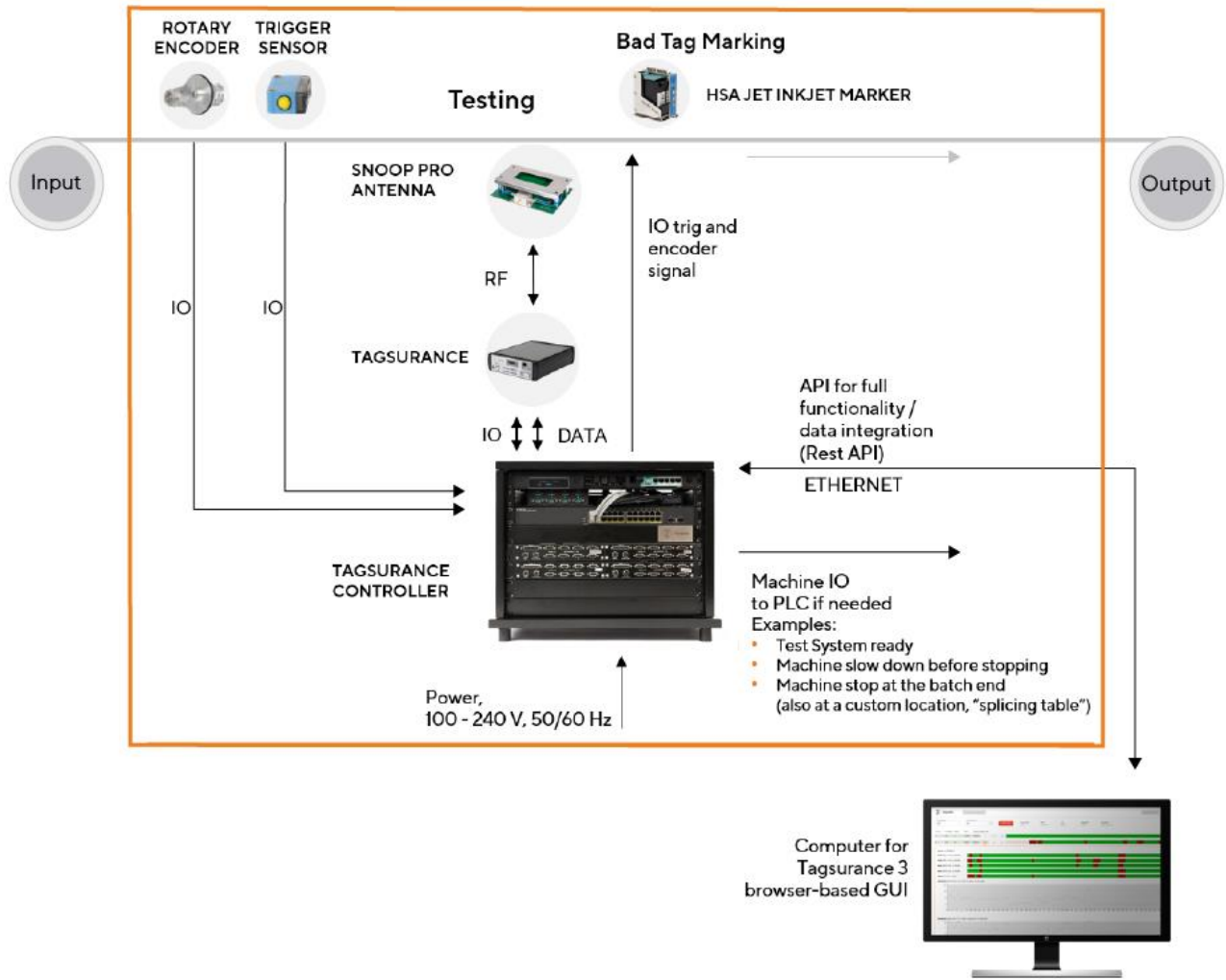

2 Terminology

Term	Meaning
Tagsurance 3	The whole system is called Tagsurance 3
Operator	<p>Person that runs the machine in production.</p> <p>Does not necessarily need to know anything about the recipe, except for loading the correct one.</p> <p>Does not need to know anything about machine configuration, but rather needs to switch shielding plates and snoops according to the recipe in use.</p>
Production engineer	<p>Plans the recipes needed for production.</p> <p>Distributes recipes to operators.</p>
Job	Contains the recipe and optional information about the job, such as job label and lot size.
Recipe	<p>Instructions for the system of what is to be done to each tag, e.g., “2 point tests and TID read” and “mark failed tags”.</p> <p>The recipe needed for a machine anywhere in the world to test and/or encode labels in a certain job by an operator as required by a production engineer.</p>
Lot	The subset of a job. The lot number is automatically incremented after predefined number of tags are processed. Lot number is included into the tag result.
Lane	<p>In the material under process: one lane of tags going through the process one by one.</p> <p>In the machine: stations that process the lane of tags going through the machine.</p> <p>Can be the only lane in a single-lane or one of the lanes in a multilane setup.</p>
Lane configuration	<p>Defines which devices are on a given lane and in which order.</p> <p>Contains the device configuration.</p>
Device configuration	Each device has its device specific settings configured here. The idea is to set it once for each device and these configurations are then just used as building blocks for lane configurations.

Lane controller	Device for controlling stations on a single lane, either the only lane in a single-lane setup or one of the lanes in a multilane setup.
Station	<p>Defines a physical device on the lane.</p> <p>Includes 1-N stages one of which must be a physical device.</p> <p>Any stage in a station before the first physical device stage is executed as soon as possible and all stages after the first physical device stage are executed as soon as possible after the triggered stage is executed.</p> <p>There are two types of stations:</p> <ul style="list-style-type: none"> • Feedback stations such as Tagsurance UHF, that affect the tags' pass/fail result • Silent stations such as marker and puncher, that do not affect the tags' pass/fail result, yet may affect the tag itself
Stage	<p>Defines any operation (related to HW device or SW process) that:</p> <ul style="list-style-type: none"> • takes in a tag data object • modifies it • outputs a tag data object <p>Is always included in a station.</p> <p>When a stage is the first physical device within a station, it is the trigger point within a station. The stages are always executed in the order they are defined within a station, and the execution stops at each first physical device within a station until that station is triggered.</p>
Task list	Instructions for each stage.
Tagsurance controller	The whole rack with everything that is inside.
PoE	Power over Ethernet. This is how Lane controller and Tagsurance SL UHF are powered to reduce number of cables and power bricks needed.
Trigger	Sensor that is used by Lane controller to sense when tags enter the process.
Rotary encoder	Sensor that is used by Lane controller to sense accurately how material is moving.

2.1 Visualization of the lanes, stations, and stages

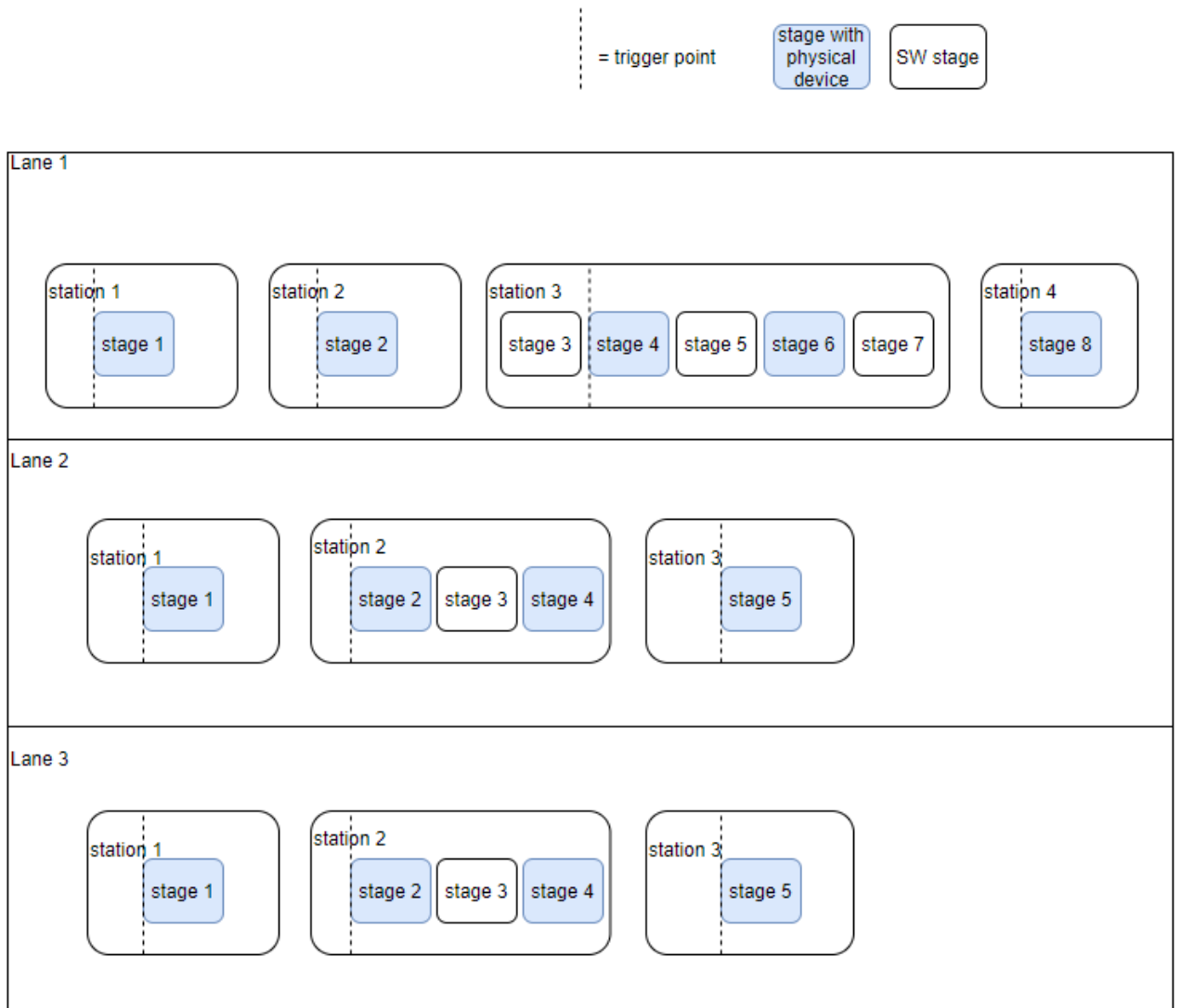

3 System components

3.1 Tagsurance controller

Tagsurance controller is the main unit of the Tagsurance 3 system. The Tagsurance controller:

- follows the flow of tags in the process;
- triggers the testing and encoding stations when the tags are on the coupling elements;
- collects the results;
- provides interfaces to the operator and a client system to take advantage of all the data.

The Tagsurance controller consists of a few components listed below. The number and configuration of components may vary according to customer requirements.

Different variants of Tagsurance 3 Controller racks:

	1 lane	1–6 lanes	1–12 lanes
Rack type	19"	19"	19"
Rack capacity	4U	8U	12U
Dimensions	See the Product catalogue.		

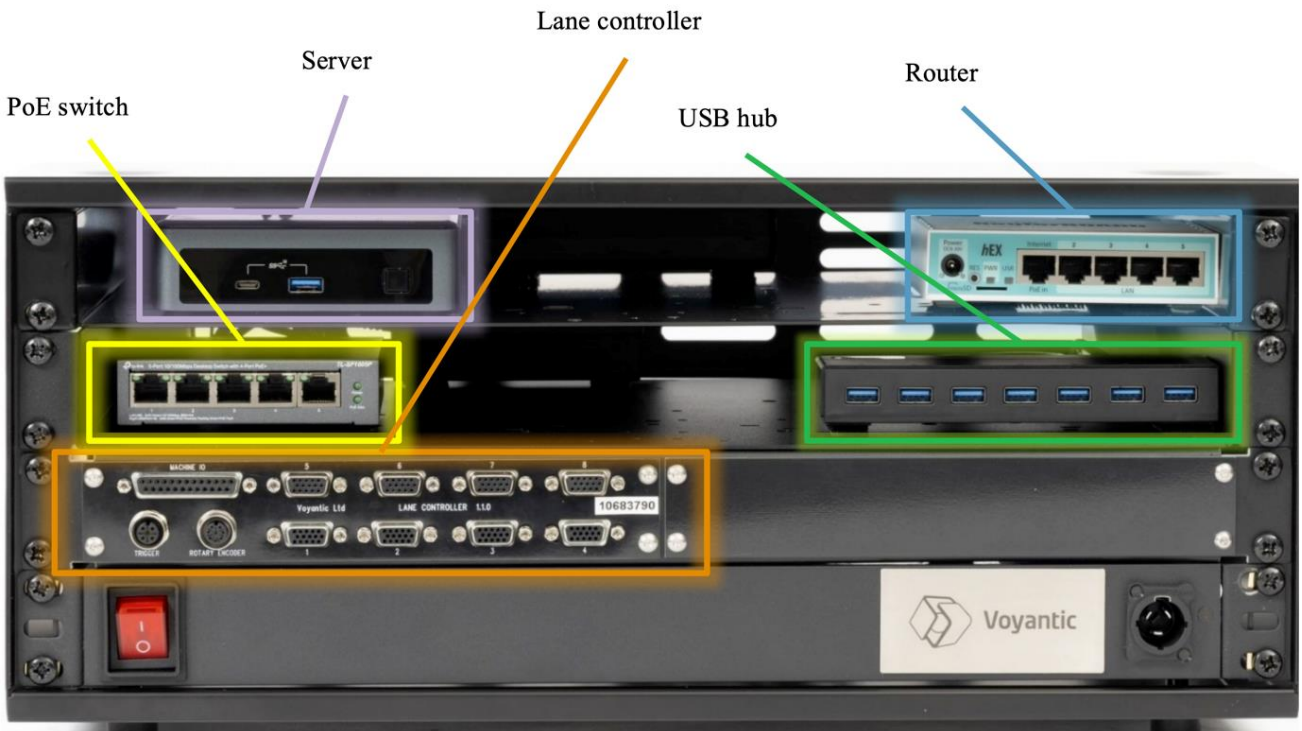



Tagsurance 3 controllers which can handle up to 4 and up to 12 lanes

3.1.1 Server

Located on the rack unit, the server is installed highest on the rack.

As the specifications for racks of different sizes may differ, the server can comply with higher system throughput with a higher number of lanes.

Note: The server is not to be connected to Internet until Voyantic updates the system from Windows-based to Linux-based. This upgrade will be required in order to update the system also after it has become available. The possibility to upgrade the system will be announced when available. The upgrade will not be mandatory, but it is highly recommended. Costs may be involved depending on the system configuration and the time of the original purchase.

3.1.1.1 Updating the software (patching and feature updates)

Updates to the software are currently handled manually following the instructions provided by Voyantic. As Voyantic adheres to semver.org in versioning, do NOT expect a major version (e.g. 1.2.3 → 2.0.0) to be backward compatible. See the API specification for detailed information on backward compatibility and API version life cycle.

3.1.1.2 Security

As there is no automated or monitored patching by Voyantic for the operating system (Windows 10 Pro) or software installed by Voyantic, the Tagsurance 3 system is not to be connected to the Internet, but rather only a local *Ethernet connection should be used.

3.1.1.3 Updates

The updates for the Windows based systems (Tagsurance 3 version 3.x) are available on [Voyantic download page](#). The user must manually download the installer and install the update to Tagsurance 3 server.

An update will be available for all customers from Windows-based systems to Linux , also allowing one-click updates including the possibility for immediate one-click rollback in case something is not working or is not satisfactory in the new version.

3.1.2 Router

The router is configured to organize the Tagsurance controller network.

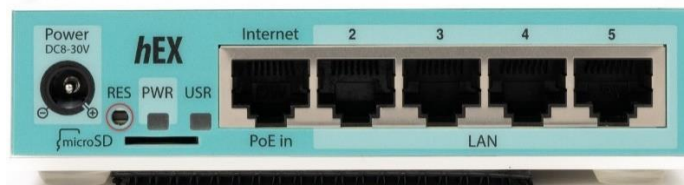

Port number	Name	Description
1 (Internet)	WAN port	Port for connecting to the customer network, with or without Internet connectivity. The network must provide IP via DHCP.
2	Direct connection	Direct connection with DHCP server with network segment 10.10.10.0/24. Meant for customers for directly connecting the computer/server that obtains the IP from the Tagsurance router and can connect to the API server through this socket.
3	Tagsurance network	Tagsurance internal network with a DHCP server. It is connected to any port in the switch and is the network where all Tagsurance devices (Tagsurance SL UHF, Tagsurance HF, etc.) will be connected to. The network is firewalled without any access outside, except to selected services on the Tagsurance server.
4	Not in use	Not in use
5	Management network	Router management

3.1.3 PoE switch

The Power over Ethernet (PoE) switch is a connection point for all Ethernet devices in the Tagsurance 3 system. The PoE switch can also be utilized as a power supply for certain devices like lane controllers. The model and power supply capacity of the PoE switch varies between Tagsurance 3 controller variants.

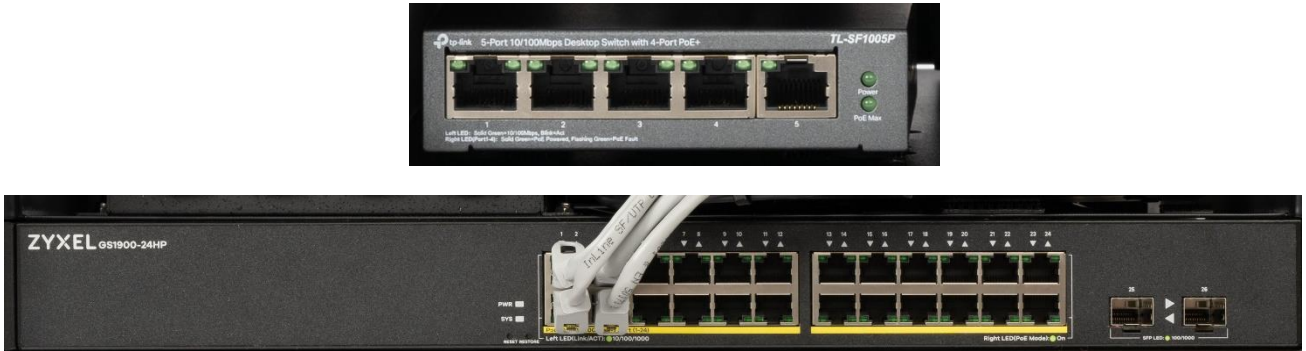

3.1.4 USB hub

The USB hub provides enough data connection points for USB devices. All lane controllers are connected to the USB hub.



3.1.5 USB-to-serial adapter

Systems with Tagsurance UHF testers are equipped with a USB-to-serial adapter because of the required RS-232 data connection. Depending on the system variant, the adapter has one or eight serial ports. The systems are preconfigured so that port 1 is COM1, port 2 is COM2, and so on. The configuration will change if the adapter is replaced after delivery.



3.1.6 Lane controller

Lane controller is a device for controlling the stations on a single lane. The number of lane controllers in the system defines the maximum number of lanes the Tagsurance 3 system can manage. Based on the lane configuration, trigger and rotary encoder signals, the lane controller observes the web movement and triggers the stations via IO connections when a tag is on top of the coupling elements.

On the front panel, the lane controller has *DE-15* connectors for each station on the lane, *M12* connectors for the trigger sensor and a rotary encoder, and *DB-25* or *DE-9* machine IO connector (version related).

There are two versions of lane controller delivered: The version 0.3.0 has five DE-15 station connectors and a DE-9 as a machine IO connector. The lane controller version 1.1.0 has eight station connectors and a DB-25 as a machine IO connector. Regardless the version numbers, both versions are in production, but Tagsurance 3 Systems are primarily equipped with lane controllers of version 0.3.0. The version 1.1.0 is currently delivered only in special cases.



Lane controller 1.1.0



Lane controller 0.3.0

See the connectors' pinout in section *10.1 Digital IO of lane controller*.

3.2 Trigger sensor

The trigger sensor is used to detect the individual labels/inlays passing through the system. The trigger signal introduces a new label to the lane controller which starts the label tracking and triggers the stations at the right time.

There are two types of trigger sensors available:

- SICK KTM-WP11172P, contrast sensor (standard delivery)
- SICK KTS-WB9114115AZZZZ, color contrast sensor



3.3 Rotary encoder

The rotary encoder is a sensor measuring the liner movement. The lane controller uses the movement information in label tracking during the process.

If the material is moved backward (reversed), Tagsurance 3 will notice it, if a job is running. The processing of tags will only start after the liner has moved forward to the position from which the reversing started.

There is one type of rotary encoder available:

- SICK DBV50E-22APA2000



3.4 Station devices

3.4.1 Tagsurance UHF

Tagsurance UHF is a device for testing the performance of UHF RFID tags. The most common protocols are supported, and the tests are deterministic. See detailed technical specifications in the *Product catalogue*.



3.4.2 Tagsurance SL UHF

Tagsurance SL UHF is a new generation of UHF RFID testers Voyantic is providing. This device does performance testing like its predecessor and soon also the encoding which enables tag personalization. See detailed technical specifications in the *Product catalogue*.



Tagsurance SL UHF has improved tag response detection which can consider a tag as bad if the tag response is significantly weaker than the responses used to be for good tags tested by the same Tagsurance SL UHF tester. This response level detection, also called backscatter strength detection, improves the test result quality especially in multilane processes. In the multilane process, the tester's sensitive receiver may hear a tag response from the simultaneously tested neighbor tags, but this feature prevents a weak response from being interpreted as a good tag

response. The backscatter acceptance level is auto-adaptive, so weak responses can only be rejected after a few tags from the job start.

3.4.3 Tagsurance HF

Tagsurance HF is a device for testing the performance of HF RFID tags, such as NFC labels. The most common protocols are supported, and the tests are deterministic. See detailed technical specifications in the *Product catalogue*.



3.4.4 Marker

[HSA Jet Micron MCHP1](#)



The print images can be designed by [MicroDraw](#) software.

3.4.5 Puncher

Voyantic does not offer punchers but rather a signal interface to fire a puncher at the correct time to crunch a chip in a failed tag. For more information on puncher signaling, see section 4.4.5 *Puncher* under Installation.

3.4.6 IO-only device

It is possible to connect other than devices provided by Voyantic as a station to the Tagsurance 3 system. The devices must implement a specific IO signal interface that the Tagsurance 3 controller uses to trigger the device when it is time to start processing the tag. The device is expected to report back whether the processing was successful or not.

The pass-fail results of IO-only devices are shown in the Tagsurance 3 operator UI and added to the logged tag results. The initialization and advanced result handling of the IO-only device must be done separate from the Tagsurance 3 system, for example, by using the device's own UI.

For more information on IO-only device signaling, see section 4.4.6 *IO-only device* under Installation.

3.5 IO Breakout

The IO breakout is an access point to IO signals between a lane controller and a station. The IO breakout provides the trigger, busy/ready and pass/fail signals at both types of outputs: NPN and PNP, and these outputs are isolated from the original signals coming from lane controller and station.

With the help of IO breakout, for example, the station trigger signal can be safely distributed to the PLC without the risk of interference with sensitive IO signals.

Note: The IO breakout has only signal outputs. You cannot input the signals to the IO breakout.



3.5.1 IO breakout versions compatibility

There are different versions of IO breakouts differentiated by color and version number. Regarding the IO breakout compatibility, the most important are the version of the lane controller and the version of Tagsurance SL UHF tester unit. The hardware version of devices can be found either on the device's front panel or back panel. The lane controllers are shown in the section 3.1.6 Lane controller, and when connecting the devices, see also 4.4.7.1 IO cable compatibilities.

IO breakout	Lane Controller	Device
Silver enclosure, version 1.0	Version 0.3 (5-ports)	<ul style="list-style-type: none"> • Tagsurance SL UHF, all HW versions • Tagsurance UHF • Tagsurance HF
Black enclosure, version 1.0	Version 1.x (8-ports)	<ul style="list-style-type: none"> • Tagsurance SL UHF version 1.x only • Tagsurance UHF • Tagsurance HF
Black enclosure, version 2.0	Version 1.x (8-ports)	<ul style="list-style-type: none"> • Tagsurance SL UHF, versions 1.x and 2.0 • Tagsurance UHF • Tagsurance HF

3.6 Strobe Light

The strobe light is an accessory to help observing the RFID tag position when the station is triggered. The strobe light is connected in between the station IO cable and the station. The duration of the flash is fixed and independent from the trigger signal pulse length.



4 Installation

This section describes how to install components to a machine and connect components to Tagsurance controller. The installation and wiring are guided on component level. An example configuration of Tagsurance system is shown in the diagram below.

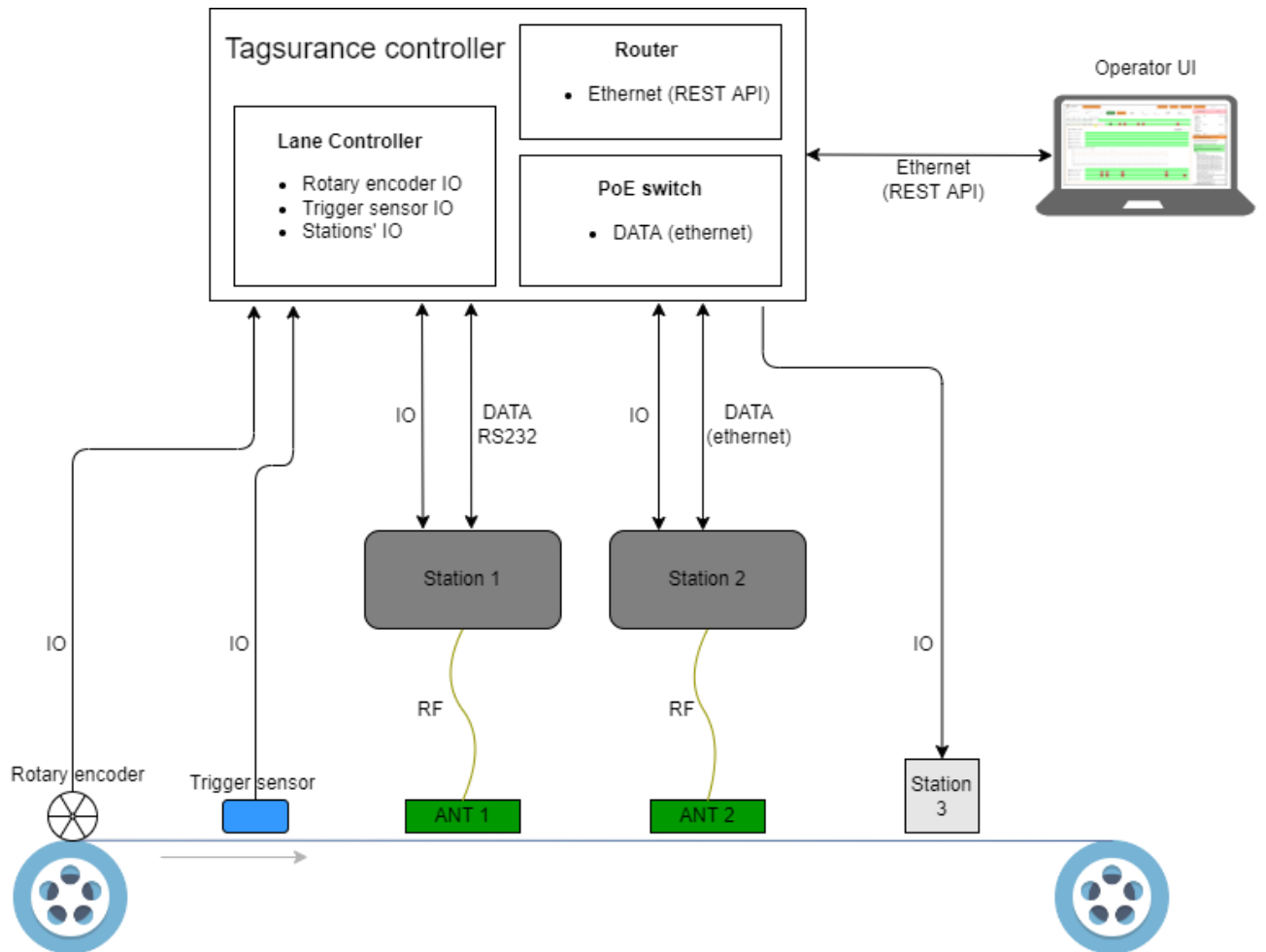

4.1 Installing Snoop Pro coupling elements

Install the Snoop Pro coupling elements on each lane as required and as they can be fitted to the machine.

The liner should touch the shielding plate. A gap between the liner and coupling element creates a risk of cross-reading.

The center line of the inlay antenna should cross the Snoop Pro coupling element's center line.

Snoop Pro has an SMA type RF connector. Make sure to fully tighten it, yet not exceeding 1 Nm torque.

4.1.1 Verifying Snoop Pro installation (verifying RF connections)

Place a reference tag on a jig to the Snoop Pro coupling element. See the image below.

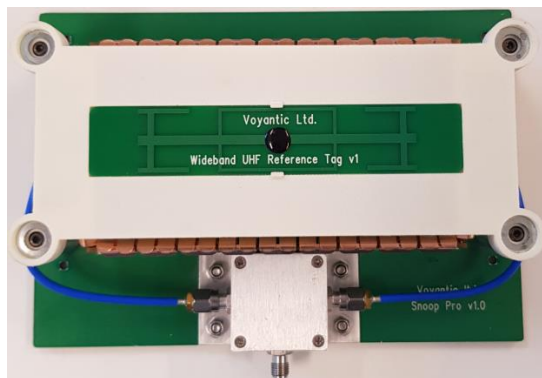

Start **Recipe Builder**. For more information, see Section 0 For the IO-only device, you need to define the distance from the trigger where you want the device to be triggered. You can configure IO signal settings, such as the trigger pulse length, delay compensation and trigger mode.

Pass/Fail signal mode must be configured to match how the connected IO only station communicates the results. The options are *'Pass and fail'*, *'Pass only'*, and *'Fail only'*. When Pass/Fail signal mode is configured to be *'Pass and fail'* both, pass and fail results, must be communicated at the IO interface. See the signal requirements in 4.4.6 IO-only device in the manual's installation section.

Choosing *'Pass only'* or *'Fail only'* forces the IO only station to reply by either with pass or fail signal. When choosing one of these options in Pass/Fail signal mode then Single result pulse timeout should also be defined which defines how long the pass or fail pulse is waited for before the result status is defined. The deadline for the result pulse is the time out defined here or the next trigger for the station, whichever comes first. See more details about the signal requirements in the section 4.4.6.

The screenshot shows a configuration window with the following settings:

- Type: IO only
- Label: (empty)
- Distance from trigger: 70 mm
- Delay compensation: 0 μ s
- Pass/Fail signal mode: Pass only
- Pass signal: Pulse
- Single result pulse timeout: (empty) ms
- Single result pulse timeout required: (checked)
- Trigger mode: Rising edge
- Pulse length: 1 000 μ s

Building a recipe“. Start creating a new recipe, and on the **Task List Editor** window, press **Get Reference**.

In a good installation:

- The threshold sweep should be visible for the entire frequency range;
- In the curve there should not be any sudden peaks or notches larger than 1 dB.

Note that the curve level may be different from installation to installation due to:

- different cable type and length
- Snoop Pro model and version
- Snoop Pro electrode extensions

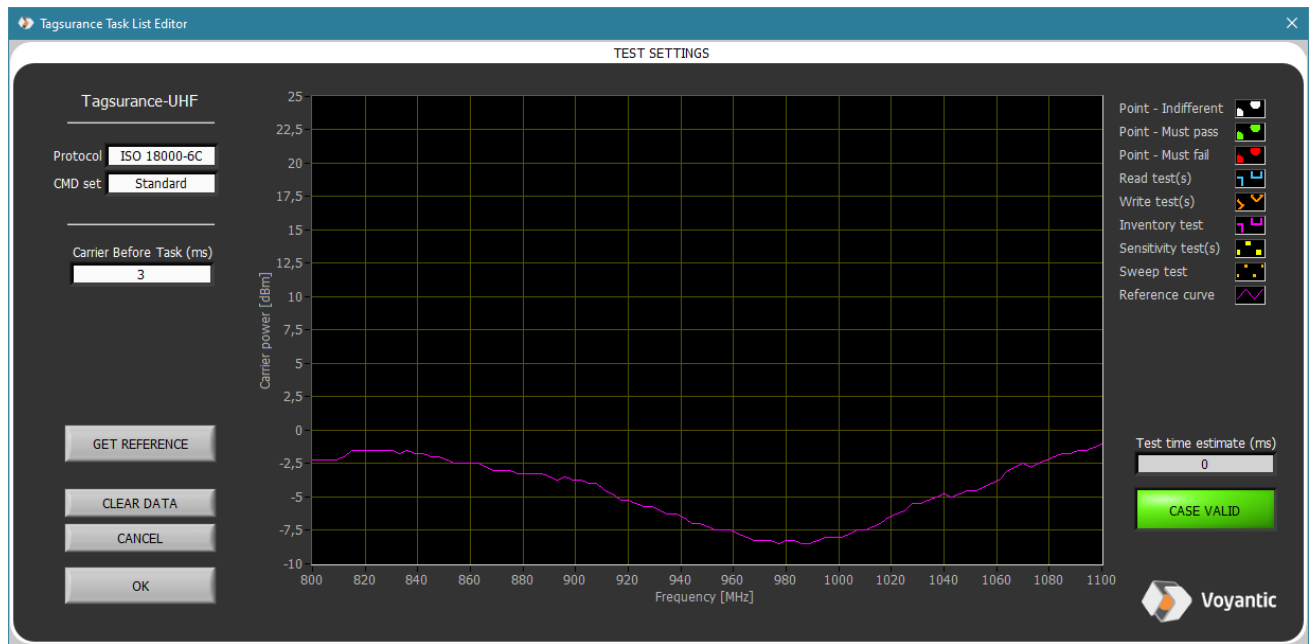

In the recipe, set sensitivity tests around the reference curve. Set the upper limit to 2 dB above and the lower limit 2 dB below the threshold. Save the recipe with the name such as **ReferenceTag_NameOfStationAndLane_Date**.

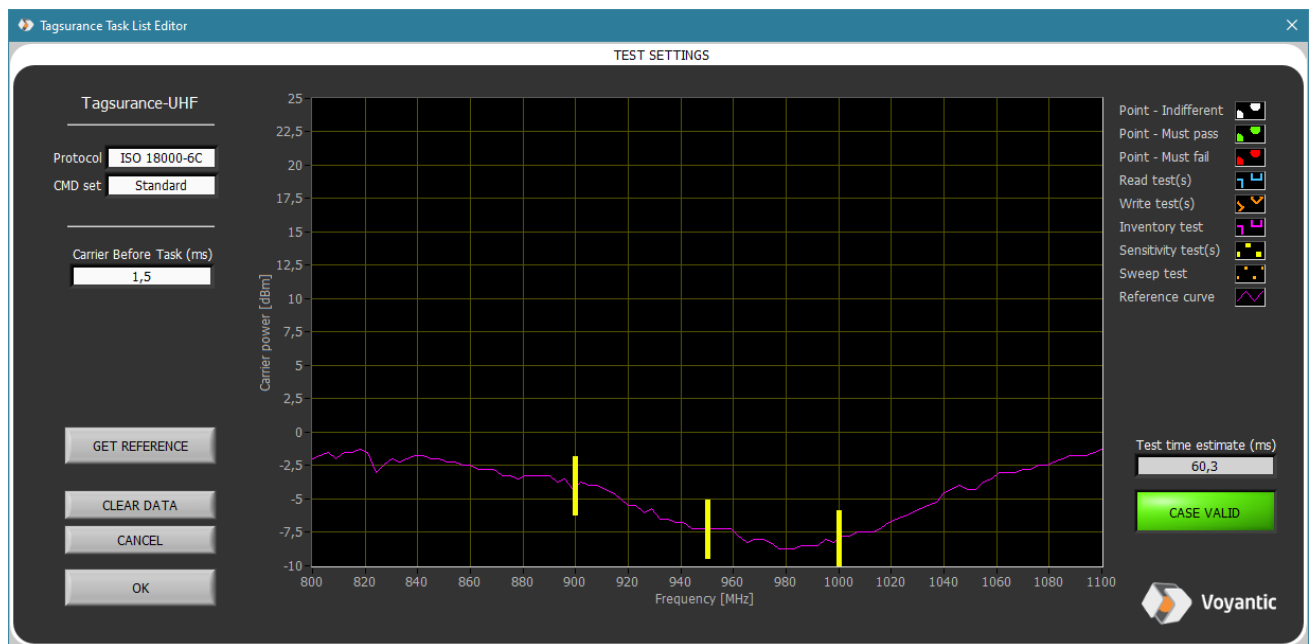

Afterwards, you can use the **ReferenceTag_NameOfStationAndLane_Date** recipe to check that the installation has not drifted and that the cables and connections are still intact. Open the **ReferenceTag_NameOfStationAndLane_Date** recipe, get the reference, and check that the reference curve is still above the set sensitivity test limits. If the installation has drifted (the reference curve is not visible or it is below or above the limits),

- check the RF cable connections and conditions;
- clean the Snoop Pro coupling element from dust;

- check that the coupling element configuration is correct (coupling element model and use of electrode extensions);
- check for any potential use of an external attenuator.

4.2 Installing the rotary encoder

Place the rotary encoder against a roll, which rotates at the liner speed. Check that the rotary encoder does not slip against the roller.

The **expected rotating direction** is shown in the images below. The expected rotation direction is known as the forward direction in lane configuration. Depending on the rotary encoder installation, you can also configure reverse direction in the lane configuration.

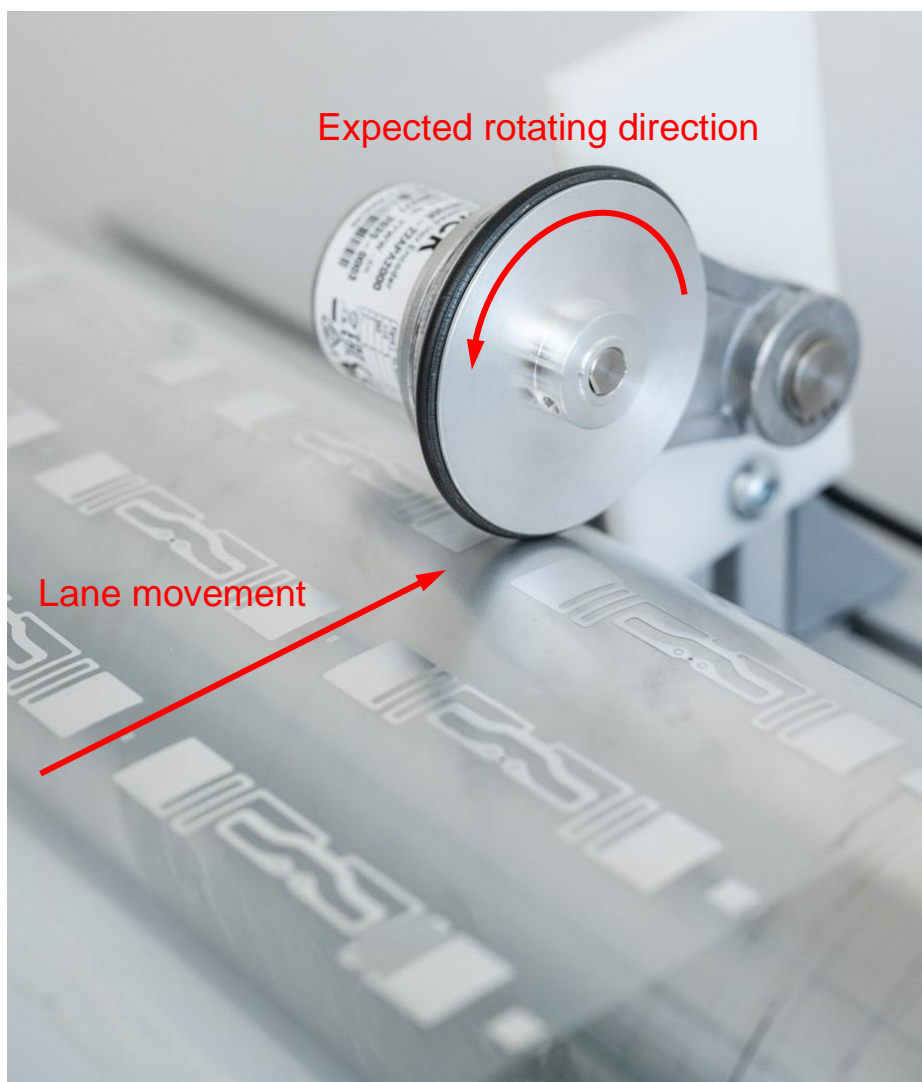

4.3 Installing the trigger sensor

The trigger sensor must be placed before the test stations. The distance from the trigger sensor to each operating station in millimeters [mm] is set in the lane configuration.

Some features require a minimum distance from the trigger to the first station to work. See details in the section 5.2.1 Distance from trigger.

4.3.1 Installing and training SICK contrast sensor

- SICK KTM-WP11172P

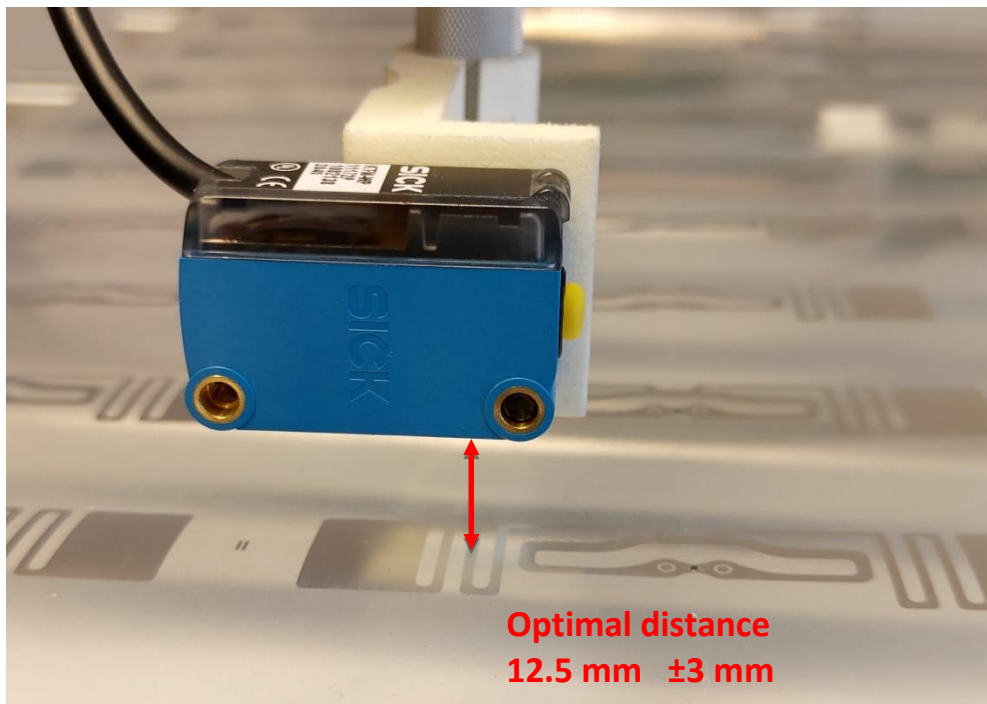

Setting the switching threshold via teach-in (static 2-point teach-in)

1. Position mark

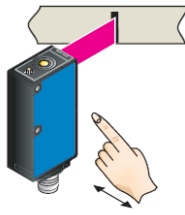

Press and hold teach-in button > 1 s.
Yellow LED flashes slowly.

2. Position background

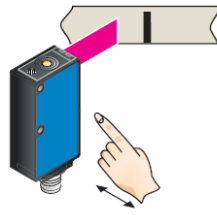

Press and hold teach-in button > 1 s.
Yellow LED goes out.

Setting the switching threshold via teach-in (dynamic)

1. Position background

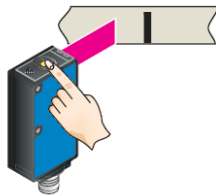

Press the teach-in button and keep it pressed.

2. Move at least one mark using the light spot

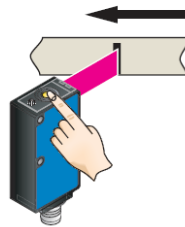

Keep the teach-in button pressed.

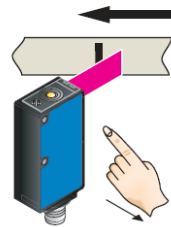

Release the teach-in button.

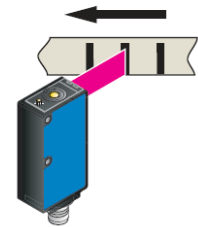

Yellow LED will illuminate, when emitted light is on the mark.

Example

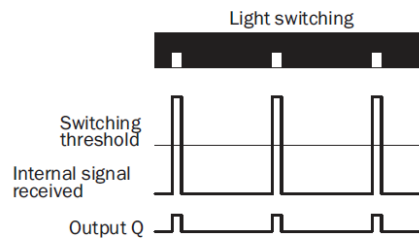
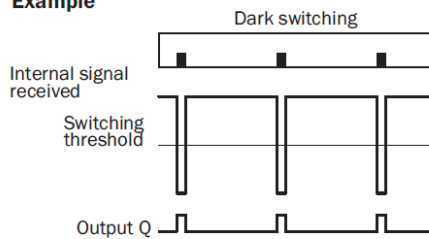

<https://www.sick.com/ch/en/contrast-sensors/ktm-prime/ktm-wp11172p/p/p455245>
(Product data sheet)

4.3.2 Installing and training SICK color contrast sensor

- SICK KTS-WB9114115AZZZZ

An example of the trigger sensor installation (SICK color contrast) is shown in the picture below.



KTS/KTX Prime - setting the switching threshold (2-point teach-in)

Suitable for manual positioning of the object to be detected, e.g. marks and background.

1. Position mark

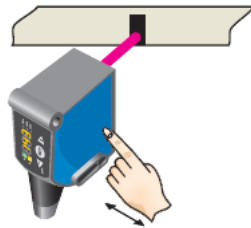

When setting the contrasts to be detected, "1st" flashes. Press set button.

2. Position background

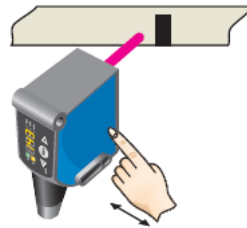

When setting the contrasts to be detected, "2nd" flashes. Press set button. The Quality of Teach is displayed.

KTS/KTX Prime - Setting the switching threshold (teach-in dynamic)

Suitable for teaching in moving objects.

1. Position background

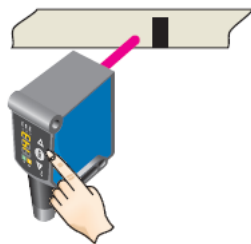

Press the Set pushbutton to start the teach-in process.

2. Move at least the mark and background using the light spot

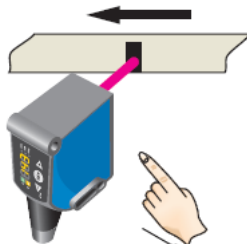

The display lights up during repeat length detection (---).

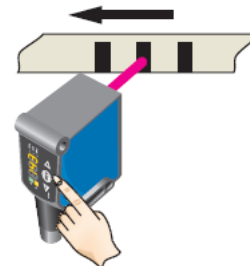

Press the Set pushbutton to end the teach-in process. The Quality of Teach is displayed.

Example

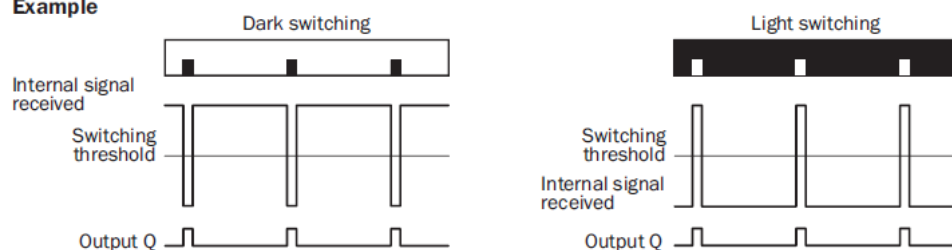

<https://www.sick.com/us/en/contrast-sensors/kts-prime/kts-wb9114115azzzz/p/p505059>
(Product data sheet)

4.4 Installing stations

Stations are the devices processing the RFID tag: Tagsurance UHF, Tagsurance SL UHF, Tagsurance HF, HSA Jet marker, etc.

Install the stations in a separate space within or close to the machine setup so that they are in the same order as their corresponding coupling elements on the lanes. In this way it will be easier to work with the system and maintain it. Note the required minimum distance between stations is 50 mm.

Note that the RF cable length from a station should not exceed 3 meters. Longer cable lengths are possible if decrease in RF performance is accepted.

As there is no compensation for cable losses, the cables should be matched to each other in length when a similar device on different lanes is in question.

4.4.1 Tagsurance SL UHF

On the device's front panel, connect:

- Ethernet cable (data and power)
 - LAN/PoE port → PoE switch in Tagsurance controller
- IO cable (IO signals)
 - I/O port → Lane controller's station port
- RF cable going to the Snoop Pro coupling element. The RF connector in Tagsurance SL UHF is an N-type connector.



4.4.2 Tagsurance UHF

On the back panel of the Tagsurance UHF device, connect:

- Serial cable (data)
 - RS-232 port → USB serial converter in Tagsurance controller
- IO cable (IO signals)
 - I/O port → Lane controller's station port
- Power cable



On the front panel of the Tagsurance UHF device, connect the RF cable going to the Snoop Pro coupling element. The RF connector in Tagsurance is an N-type connector.

4.4.3 Tagsurance HF

4.4.3.1 Version 3.x

Tagsurance HF version 3.x has all the connectors on the front panel. Connect:

- Ethernet cable (data and power)
 - LAN/PoE+ port → PoE (Ethernet) switch in Tagsurance controller
- IO cable (IO signals)
 - I/O port → adapter ¹⁾ → Lane controller's station port
- RF cable going to the Snoop Pro HF coupling element. The RF connector in Tagsurance HF is an N-type connector.



1) The adapter is a 50 cm long cable with D15 connectors at both ends. The adapter is always required when connecting Tagsurance HF version 3.x to Lane controller version 0.3 (5 station ports) The existence of IO breakout does not affect, and the adapter is required. Do not use the adapter with any other Lane controller version.



There is also an 18-24 VDC connector in Tagsurance HF version 3.x, however, it is not needed when the device is PoE powered. While not recommended, it is safe to have both power supply options connected at the same time.

4.4.3.2 Versions 1.x and 2.x

On the back panel of the Tagsurance HF device, connect:

- Ethernet cable (data)
 - LAN port → PoE (Ethernet) switch in Tagsurance controller
- IO cable (IO signals)
 - I/O port → D25-to-D15 adapter → Lane controller's station port
- Power cable



On the device's front panel, connect the RF cable going to the Snoop Pro HF coupling element. The RF connector in Tagsurance is an N-type connector.

4.4.4 Marker

Connect the branched IO cable from lane controller’s station port to the HSA Jet Micron marker. The cable has 2 pieces of D9 connectors at the marker end, as shown in the picture below. The connectors are labelled as “I/O” and “ENC”, respectively, at HSA Jet Micron marker. Connect also the power cable.



4.4.5 Puncher

The IO cable to the puncher (rev2) has 4 pins at the puncher end. The available output signal (white wire) is an NPN type trigger (active on low). The shield is grounded.

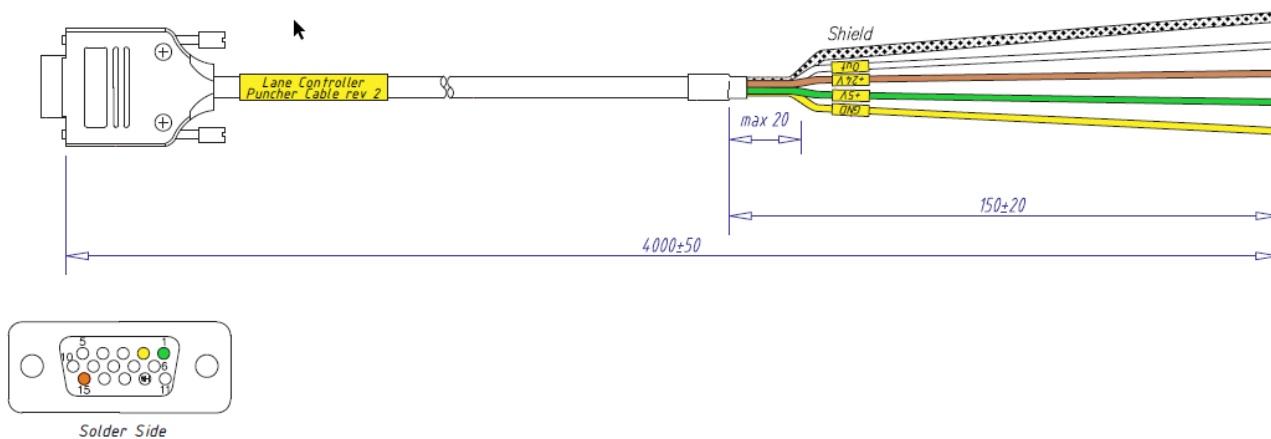

The trigger signal is not meant to drive the puncher directly but a relay in between. See the current limits for signals in Section 10.1.6 Output signal current limits.

4.4.6 IO-only device

The IO-only device will be connected to the station port of the lane controller. There are three IO signals: trigger, pass, and fail. The lane controller sends the trigger pulse, the length of which is adjustable in the lane configuration. The IO-only device is expected to reply the result by sending either a pass or failure pulse to the lane controller. When neither a pass nor failure signal is detected, the result is interpreted as a failure and shown as an error in the operator UI.

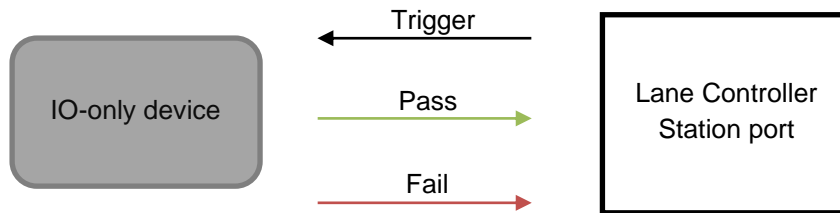

For the pass and failure signals, the minimum pulse length is 1 ms. See the signal polarities and voltage levels in Section 10.1.4 Station connector.

For the correct result signal interpretation, the pass or fail pulse must be sent before detection deadlines, and the result pulse must be completed before the deadline, i.e. the signal must return to passive state. There are three different modes for the result signaling: 'Pass and fail', 'Pass only', and 'Fail only'. See the mode details

The error results are handled as fail results. The "error" tags can be marked as bad ones by a bad tag marker, and the error results represent bad tags in yield calculations.

In the following signal diagrams, the signals are PNP type, active high (> 5 VDC) and passive low (< 2 VDC). See the voltage level details in the section 10.1.4 Station connector.

4.4.6.1 Pass and fail

Either pass or fail pulse must be sent before the next trigger. In case, there are both pass and fail pulses, the first one defines the tag status. However, if the result pulses overlap each other or the next trigger, the tag result is interpreted as an error. The tag result will be an error if neither result pulses are detected.

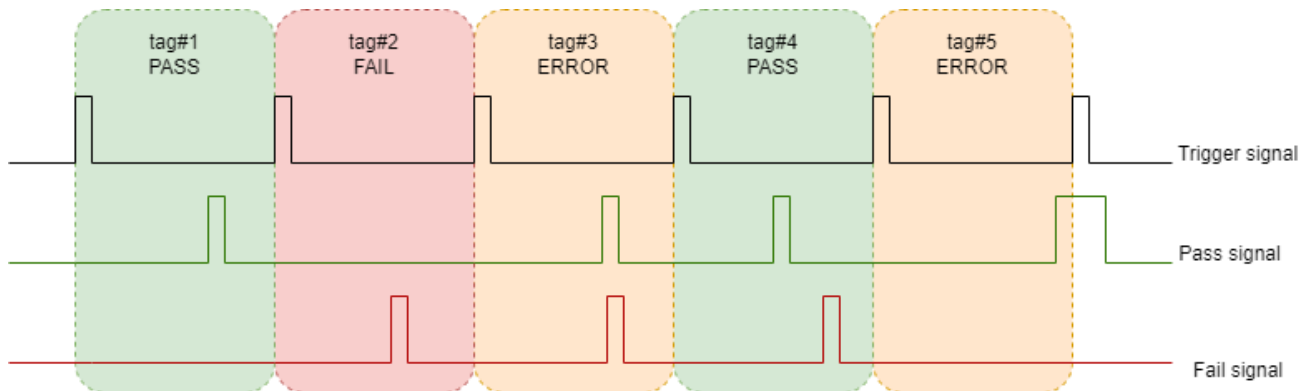

4.4.6.2 Pass only

In the 'Pass only' mode, the deadline for the result pulse is the defined timeout value or the next trigger signal, whichever comes first, otherwise, the tag is interpreted as fail. If the result pulse overlaps the deadline, the tag status will be an error.

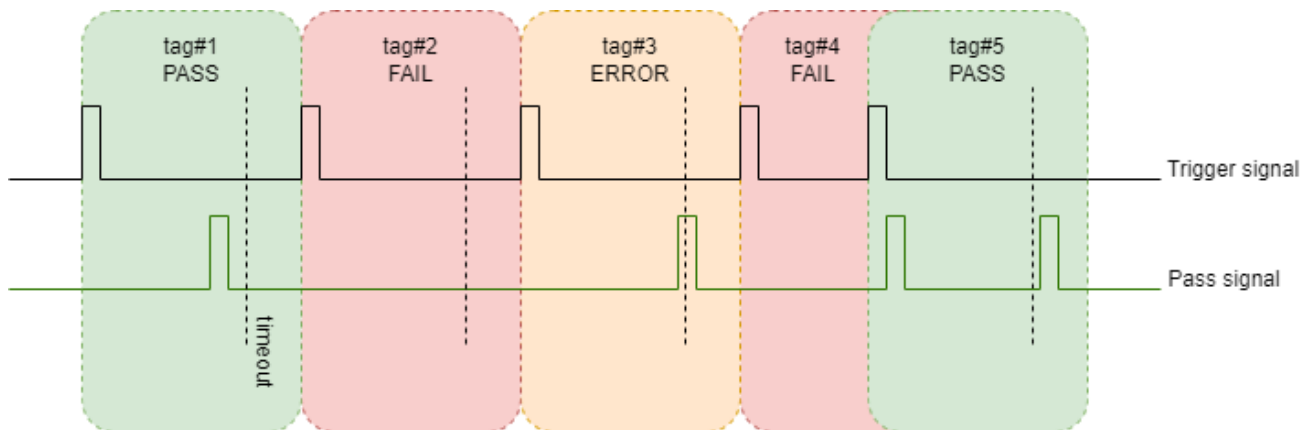

4.4.6.3 Fail only

In the 'Fail only' mode, the deadline for the result pulse is the defined timeout value or the next trigger signal, whichever comes first, otherwise, the tag is interpreted as fail. If the result pulse overlaps the deadline, the tag status will be an error.

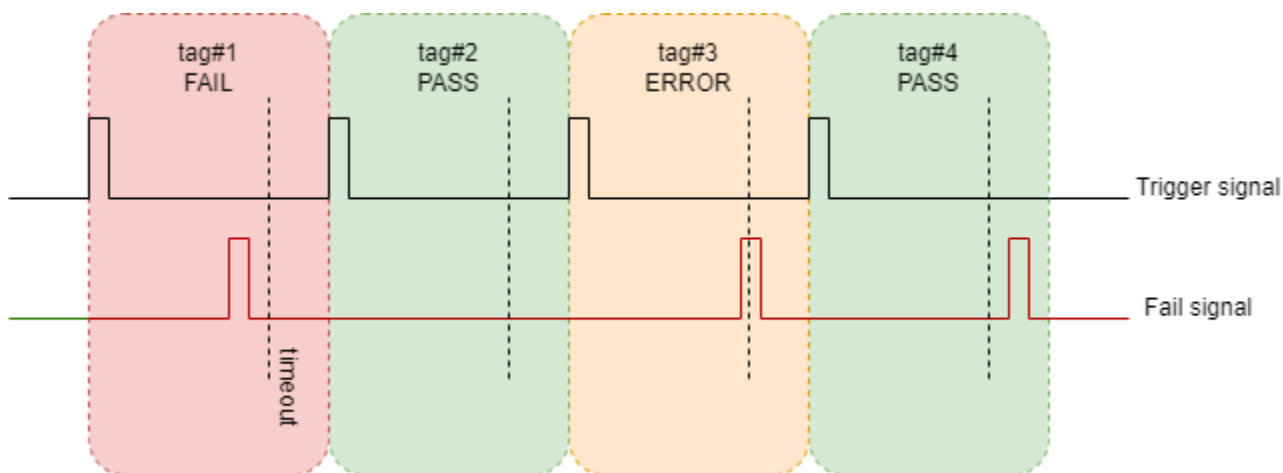

4.4.7 IO cable for Voyantic devices

The IO signals of all Voyantic devices, Tagsurances, are connected to the lane controller by using the IO cable having DA-15 (pins in two rows) and DE-15 (pins in three rows) connectors. Similarly, the ends are labelled as *Voyantic device* and *Lane Controller*. The IO Cable has customized connections to make Voyantic devices compatible with the lane controller's pinout.



4.4.7.1 IO cable compatibilities

There are two revisions of the IO cable between lane controller and Voyantic device. The required revision of the cable depends on the lane controller version. See the section 3.1.6 Lane controller. The cable revisions are differentiated by the cable color.

Lane Controller	IO cable color
Version 0.3 (5 station ports)	Beige
Version 1.1 (8 station ports)	Grey or Black

4.5 Connecting cables

4.5.1 Rotary encoder and trigger sensor

Connect the rotary encoder and trigger sensor to the M12 connectors above the lane controller's station connectors. When there is only one trigger for all lanes, it does not matter which lane controller the trigger is connected to. It does not matter to which lane controller the rotary encoder is connected. There can only be one trigger sensor and one rotary encoder connected to the system.

4.5.2 Stations

Connect the stations' RF and power cables as instructed in their manuals. The installation of Voyantic devices is shown in the section 4.4 .

Connect the IO cables from the lane controller's station ports (DE-15, 15 pins in 3 rows) to each station in the same order the stations are physically located on the lane. Each lane has a dedicated lane controller.

In a 5-port lane controller the leftmost port is station 1. In an 8-port lane controller the station ports are numbered.

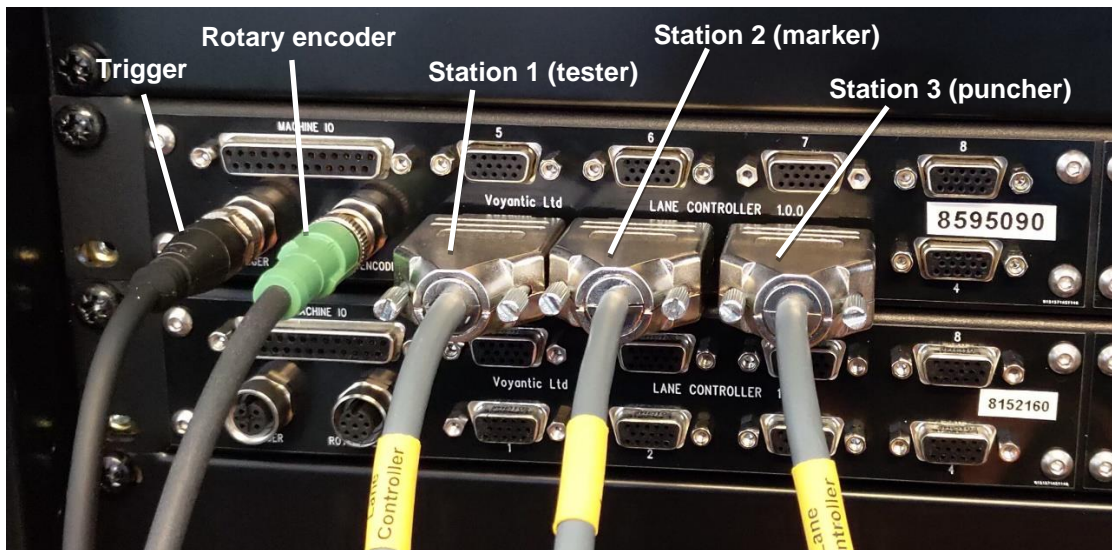

Connect the stations' data (Ethernet/serial) cables (marked yellow in the picture below):

- Tagsurance UHF to serial port connector
- Tagsurance SL UHF to PoE enabled port of the Ethernet switch
- Tagsurance HF to the Ethernet switch

4.5.3 IO Breakout

Connect the IO breakout in between the lane controller and the station. Connect the IO cable from station to IO breakout instead of lane controller, and the IO cable with DE-15 connectors at

both ends (male and female) from lane controller's station port to IO breakout. The latter IO cable is provided together with the IO breakout.

The station's IO signals can now be connected from the IO breakout's green connector to the PLC. Either PNP or NPN output can be chosen depending on the interface of the machine. See the pinout and details in the section 10.3 .



4.5.4 Strobe Light

The strobe light cable is a cable extension which has two DA-15 connectors, male and female connector. Connect the strobe light cable in between the station IO cable and the station itself.

4.5.5 Machine IO

The Tagsurance controller can be configured to communicate with the production machine (PLC) via machine IO connector's digital signals, for example, to stop the machine when a batch is fulfilled.

All configured outputs of the machine IO have both output types: NPN and PNP. See the pinout in Section 10.1.5

The signal configuration is described in Section 5.1.1.

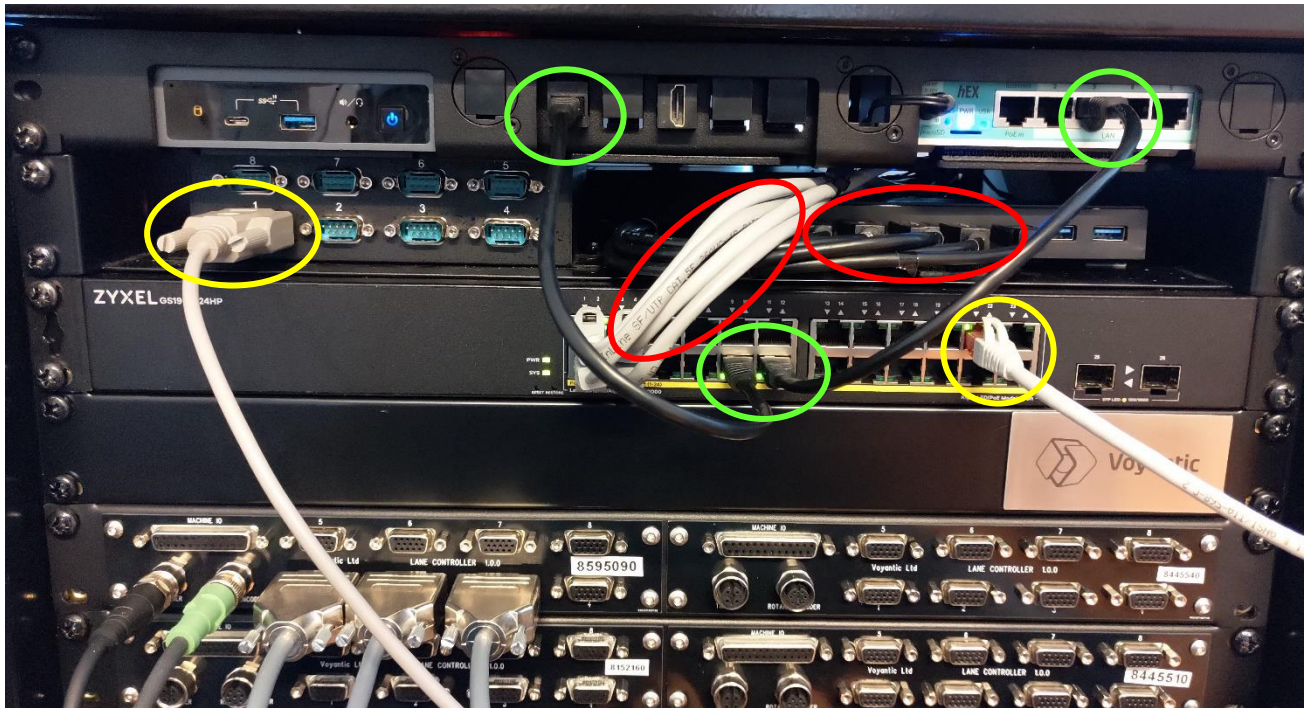

The data cables (serial/Ethernet/USB) of the stations are connected to Tagsurance controller's PoE (Ethernet) switch, USB-to-serial adapter, or USB hub.

4.5.6 Lane controllers

Connect the lane controllers' Ethernet and USB cables (marked red in the picture above) to the PoE enabled ports of the Power-over-Ethernet (PoE) switch, and USB hub. In the picture above, four lane controllers are connected.

4.5.7 Tagsurance network

Connect Ethernet cables between the router, Ethernet switch, and Tagsurance server (marked green in the picture above).

- Router port #3 → Ethernet (PoE) switch
- Ethernet switch → Tagsurance server (computer in the Tagsurance system)

Depending on the Ethernet switch model, not all ports are PoE powered, and in case you have several PoE devices, the Ethernet switch may run out of PoE ports. On the Ethernet switch end, you can use non-PoE ports for the Tagsurance network connections listed above.

See the router description in Section 3.1.2 *Router*.

4.6 Connecting to the Tagsurance system

4.6.1 Direct connection

- Connect an Ethernet cable from your computer to **router port #2**.
- Browser based operator UI is available in <https://10.10.30.10>

You may need to allow an exception in your browser before the operator UI will open. Depending on your computer settings, you may also have to close the WiFi connection of your computer before successfully establishing a connection.

4.6.2 Network connection

Note: Due to automatic updates and restarts, as Tagsurance controllers have their server running on Windows, Voyantic does not recommend connecting them to the Internet. An automatic restart will stop the job.

Connect your network to router port #1.

You can configure the IP address of the router port #1 in the operator UI settings.

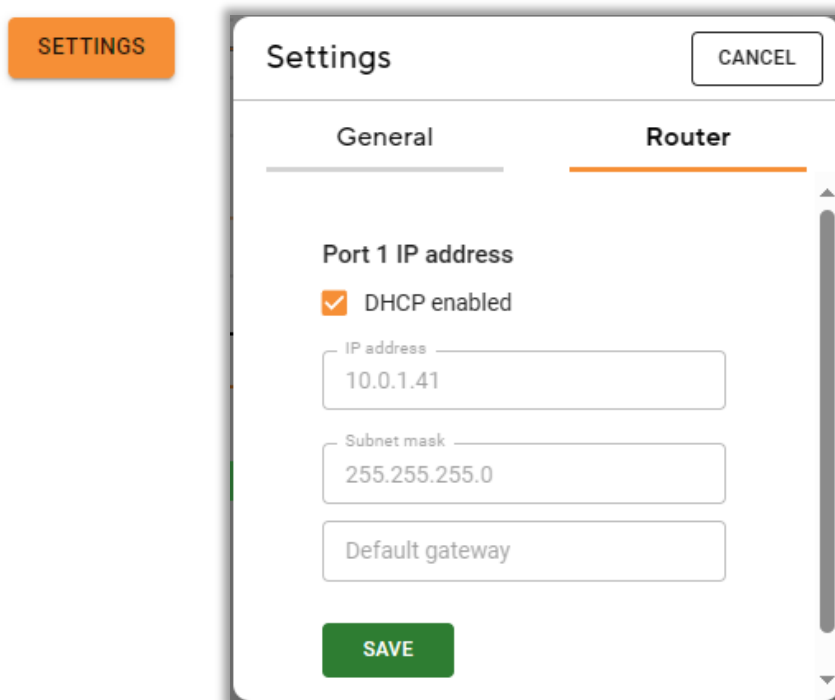

Note: IP address assignment changes require a full system reboot to prevent network issues. The system may seem to work perfectly but without reboot there may be e.g., 1% packet loss which is not good.

How to reboot: Press the power button on server and when it is shut down, cycle the power of the whole Tagsurance 3 rack and then power the server back on.

Through a network connection, the operator UI, REST API, and API documentation are available as they are through the direct connection, but the IP address is different. The IP address is either provided by the DHCP service, or it is a static IP defined by the user). In the example of the picture above, the operator UI is available in <https://10.0.0.86>.

To make the Tagsurance system always available from the same address, it is a good idea to configure your network to give the same IP address to the Tagsurance system. If your network configuration so allows, you can configure the router port #1 to have a static IP address.

Note: The IP address range 169.x.x.x is not supported. Select a static address outside of this range.

The information screen on the right in the operator UI main view shows router information including the IP address that the router has received from the network, for example WAN IP address 10.0.0.103/24. The same information, including router's MAC address, is available in the status endpoint.

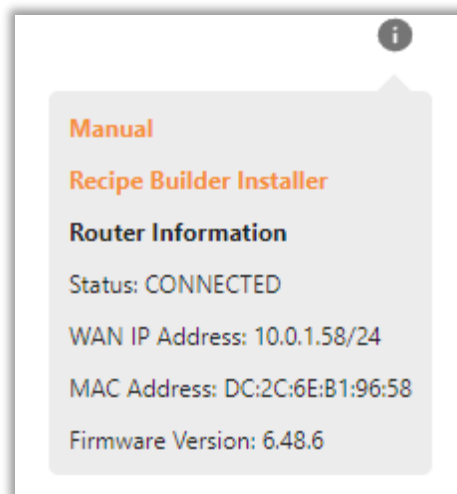

You can connect your own PC to the router using a direct connection as described in Section 4.6.1 and open the Operator UI in a browser window to see the IP address of Tagsurance controller. You can also query the current IP address from the status endpoint of the REST API by using a direct connection.

4.6.3 APIs

You can integrate to the Tagsurance system via APIs. Tagsurance system offers REST API and AsyncAPI. The REST API is a call-response type of communication. With the REST API, you can for example save a lane configuration, start a job, finetune the station triggering location and export data after the job is stopped.

In the AsyncAPI, you can subscribe to channels from which data is streamed out. From the AsyncAPI streams you can receive metrics like lane speed and process yield several times per second, and tag results when they are ready without separate requests. You can use APIs parallel as you wish.

You can connect to APIs at the same address where the operator UI is available, that is described above. API documentation is available at the same address as operator UI. For example, through the direct connection in

- <https://10.10.30.10/api-docs>
- <https://10.10.30.10/async-api-docs>

5 Building lane configuration

For building a lane configuration, the system needs to know:

- How many lanes are in use;
- Lane controllers' serial numbers;
- Which stations are connected and their serial numbers/COM ports, etc.;
- Distance from the trigger to each station on the lane, coupling element / marker / etc.

To modify or change your lane configuration in the operator UI, click **Lane Configurator**.

Build a lane configuration to match your machine configuration. Add as many lanes as you have on your machine, and add devices as stations in the same order they are mounted on the machine. One lane is configured horizontally, the devices being next to each other. The column header shows the station connector of the lane controller which the device must be connected to. The lanes are stacked on top of each other.

The screenshot displays the Lane Configurator interface. On the left, there are 'Common settings' and 'Locations' sections. The 'Common settings' section includes a 'Lane controller type' dropdown set to 'Lane controller 0.3 / 1.X' and a 'Rotary encoder direction' dropdown set to 'Forward'. The 'Locations' section includes a 'Location name' input field with 'Cutting table' and a 'Distance from trigger' input field with '980 mm'. At the bottom left, there are 'IMPORT' and 'EXPORT' buttons. On the right, a grid shows two lanes. Lane 1 is configured with a 'Lane controller' (Type: Tagsurance SL UHF, Label: TSU-1005, Serial number: 8595090) and two 'Station connectors' (Station connector 1: Type: Tagsurance SL UHF, Label: TSU-1005, Distance from trigger: 315 mm; Station connector 2: Type: Marker, Label: Marker-1, Distance from trigger: 600 mm). Lane 2 is configured with a 'Lane controller' (Type: Tagsurance SL UHF, Label: [blank], Serial number: [blank], Serial number required) and two 'Station connectors' (Station connector 1: Type: Tagsurance SL UHF, Label: [blank], Distance from trigger: 375 mm, Serial number: [blank], Serial number required; Station connector 2: Type: Marker, Label: [blank], Distance from trigger: 700 mm). Plus (+) and minus (-) icons are used to add or remove lanes and stations.

The common settings and locations for lane controllers in the left column are common to all lanes, that is lane controllers.

You can add (+) a new lane at any position before or after the current lanes or remove lanes (x).

1. Click (+) to add a new lane, and the Lane Editor dialog opens.

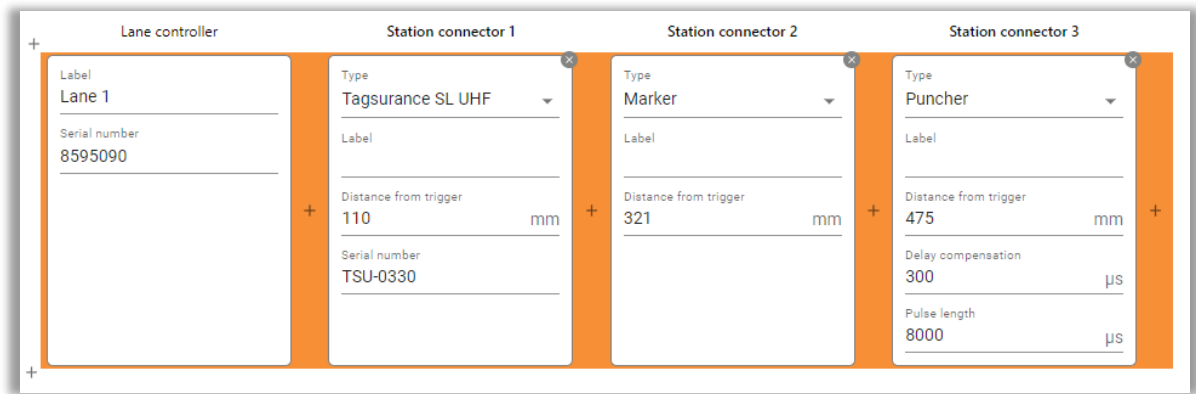

2. Edit the information according to your needs.

Note: When filling in information for your configuration, the UI will highlight a field in red if some mandatory information is missing.

5.1 Lane controller

In the operator UI, select the lane controller that is in use and insert the correct serial number. The serial number is located on the lane controller's front panel.

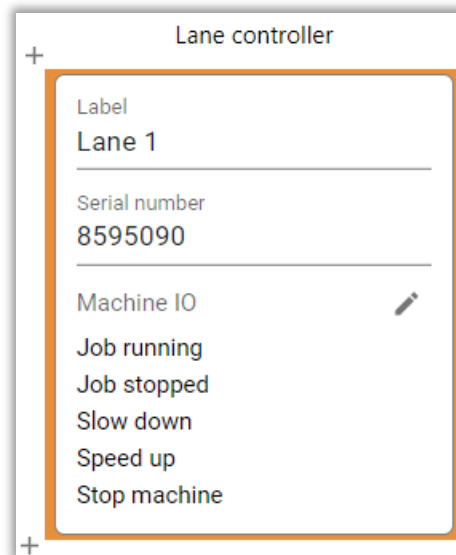

5.1.1 Machine IO

You can define machine IO settings that are specific to each lane controller. You can name the actions as you wish.

This view shows what happens when the conditions defined by action triggers are met and the actions defined here are set to happen. Based on the definitions made, the following actions are triggered in the example below:

- *When action Job running is triggered, the pin pair 14/15 is set to active state;*
- *When action Job stopped is triggered, the pin pair 14/15 is set to passive state;*
- *When action Slow down is triggered, the pin pair 16/17 is set to active state;*
- *When action Speed up is triggered, the pin pair 16/17 is set to passive state;*
- *When action Stop machine is triggered, the pin pair 18/19 is pulsed to active state for 10 ms.*

Machine IO
CANCEL
SAVE

Action name	Pin pair	Initial state	Target state	Type	Duration	
Job running	14/15	PASSIVE	ACTIVE	LATCH		×
Job stopped	14/15	PASSIVE	PASSIVE	LATCH		×
Slow down	16/17	PASSIVE	ACTIVE	LATCH		×
Speed up	16/17	PASSIVE	PASSIVE	LATCH		×
Stop machine	18/19	PASSIVE	ACTIVE	PULSE	10 ms	×

+

Each lane controller has its own specific machine IO. It is active during a job only if so specified in a recipe as part of a job. In other words, the actions defined in a machine IO can only be triggered if the lane controller in question is active.

5.2 Stations

You must set the stations in the same order as they appear on the machine.

1. Select the device type.
2. Set distance from the trigger [mm].
3. Fill in the device type specific configurations.

5.2.1 Distance from trigger

The distance from trigger is calculated from the location where the trigger sensor detects a tag to the location where a station operates, e.g. the location where Tagsurance SL UHF tests the tag.

Tip: Utilize the rotary encoder to measure the distance from trigger. Move the lane to the position where the trigger sensor has just detected a new tag. Start a job in Tagsurance 3 system and run the lane forward until the tag is at the desired station location. The travelled distance is shown in the operator UI.

The minimum required distances from trigger and between stations ensure the correct operation of all system features. See the requirements in Section 10.4 Station locations.

The exception to requirements is the 0 mm distance from trigger value that sets the system to trigger the station instantly after the lane controller receives a trigger signal. The use case for this feature is in stop-and-go machines. The machine stops the line when a tag is at the testing location, and triggers Tagsurance 3 system. From this point on, Tagsurance 3 system triggers the tester, indicates to the machine when the test is done and line can move again, and is responsible for the bad tag marking. The distance from trigger of a marker is now measured from the testing station, that is the location where Tagsurance 3 system receives the trigger signal. The rotary encoder existence is mandatory for tag movement detection.

5.2.2 Tagsurance UHF 1.x

As a prerequisite for the configuration, you need to check in which COM port each Tagsurance is. Each port on the USB-to-serial converter is numbered, and the same numbering applies for the software. If there are two 8-port USB-to serial adapters, then the leftmost is 1-8 and the rightmost 9-16 (1=9, etc...).

If you are unsure for any reason and you need to check without checking the cables which Tagsurance UHF 1.x is in which COM port, you can do this with Tagsurance 3 *Recipe Builder*:

1. Add a TS-UHF device.
2. Open *Tagsurance Task List Editor*.
3. Select **Get Reference**.

The software will show a list of available Tagsurance UHF devices and corresponding COM ports.

Set the distance from the trigger to the point over coupling element (with the shielding plate of your choice) where the test should start when the tag passes the coupling element. Note that usually some 2–5 mm of air between the shielding plate leading edge and the tag trailing edge should be left to ensure stable enough measurement.

Other device settings should be left in the default mode.

5.2.3 Tagsurance HF

Enter the serial number as written on the device's back panel. It looks like this: TS-HF-1234, always starting with "TS-HF-" and ending with four digits. Note that the letters are in upper case.

Set the distance from the trigger to the point over coupling element (with the shielding plate of your choice) where the test should start when the tag passes the coupling element. Note that usually some 2–5 mm of air between the shielding plate leading edge and tag trailing edge should be left to ensure stable enough measurement.

5.2.4 Tagsurance SL UHF

Enter the serial number as written on the device's front panel. It looks like this: TSU-1234, always starting with "TSU-" and ending with four digits. Note that the letters are upper case.

Set the distance from the trigger to the point over coupling element (with the shielding plate of your choice) where the test should start when the tag passes the coupling element. Note that usually some 2–5 mm of air between the shielding plate leading edge and tag trailing edge should be left to ensure stable enough measurement.

5.2.5 Marker

For the marker, you only need to set the distance from the trigger in the system configuration.

5.2.6 Puncher

For the puncher, you can set the following in the lane configuration:

- *Distance from trigger*: This parameter defines the distance from the trigger point where the puncher should activate.
- *Type*: You can define the trigger pulse length in two ways:
 - *Time-based Pulse Length*: If the pulse length type is set to time, then the corresponding Pulse length parameter should be defined in microseconds.
 - *Distance-based Pulse Length*: If the pulse length type is set to distance, then the Pulse length parameter should be defined in millimeters.
- *Delay compensation*: It may be necessary to use the delay compensation to advance the triggering of the moment puncher (in time) due to its inherent inertia. This ensures that the puncher will activate at the correct moment, compensating for any delays in the system.

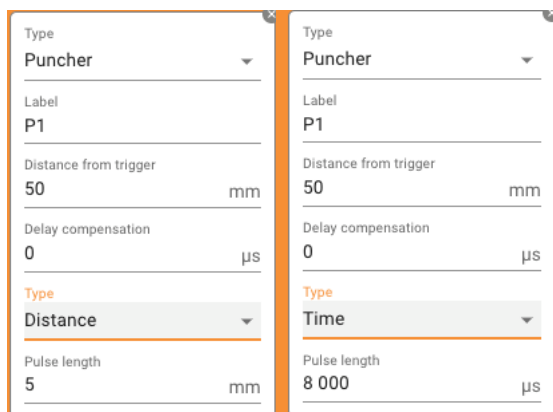

Note: When configuring a puncher with a distance-based trigger pulse length (e.g. 50mm), the system applies this pulse length in both forward and backward directions.

Scenario:

- The puncher is set to activate and stay triggered for 50mm.
- As the lane travels forward, the puncher will remain active for the specified 50mm, which is the expected behavior.
- However, if the lane moves backward more than 50mm, the puncher might trigger on a previous tag.
- When the lane resumes moving forward, the puncher will not re-trigger on the original tag since it already counted the initial 50mm pulse length.

To avoid this issue, ensure that the lane movement is controlled to prevent backward travel exceeding the configured pulse length distance, or adjust the configuration as needed for your specific setup.

5.2.7 IO-only device

For the IO-only device, you need to define the distance from the trigger where you want the device to be triggered. You can configure IO signal settings, such as the trigger pulse length, delay compensation and trigger mode.

Pass/Fail signal mode must be configured to match how the connected IO only station communicates the results. The options are *'Pass and fail'*, *'Pass only'*, and *'Fail only'*. When Pass/Fail signal mode is configured to be *'Pass and fail'* both, pass and fail results, must be communicated at the IO interface. See the signal requirements in 4.4.6 IO-only device in the manual's installation section.

Choosing *'Pass only'* or *'Fail only'* forces the IO only station to reply by either with pass or fail signal. When choosing one of these options in Pass/Fail signal mode then Single result pulse timeout should also be defined which defines how long the pass or fail pulse is waited for before the result status is defined. The deadline for the result pulse is the time out defined here or the next trigger for the station, whichever comes first. See more details about the signal requirements in the section 4.4.6.

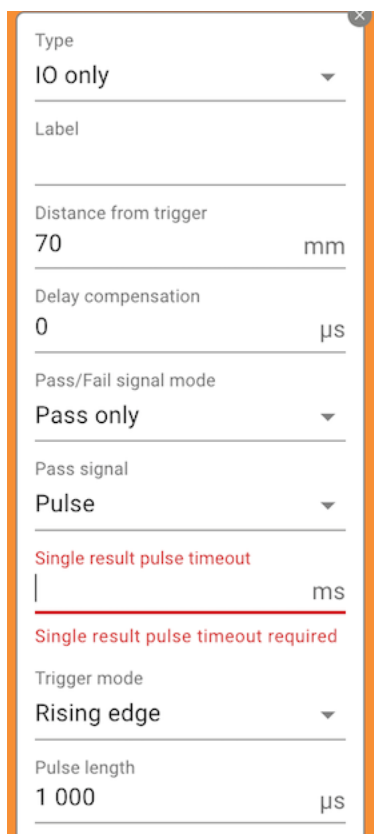

The screenshot shows a configuration window for an IO-only device. The settings are as follows:

Type	IO only
Label	
Distance from trigger	70 mm
Delay compensation	0 μ s
Pass/Fail signal mode	Pass only
Pass signal	Pulse
Single result pulse timeout	ms
Single result pulse timeout required	
Trigger mode	Rising edge
Pulse length	1 000 μ s

6 Building a recipe

The recipe is a configuration which defines device types to be used and the actions to be done for RFID tags within the process. Tagsurance Recipe Builder is a software for the recipe creation. Tagsurance Recipe Builder comes in a separate installation package (see the information bubble shown in Section 4.6.2) and can be installed on any Windows PC. The reference sweep measurement in Tagsurance task list editors works only on Tagsurance 3 server computer because of the required data connection between measurement device and computer.

6.1 Recipe Builder overview

The Recipe Builder is a graphical tool for creating compatible test recipes for Tagsurance 3 system. It consists of 4 main parts:

- **Control panel:** It allows to insert a name for the recipe as a label, save the current configuration, load a previous test recipe and clear the current worksheet.
- **Stage builder:** It allows to configure the necessary stations for a recipe by defining them in correct order, defining the settings like task lists and connecting input and output variables.
- **Variable Manager:** It allows to define all the necessary variables (System, Data Conversion, File origin and Incremental) for a specific recipe.
- **Mapping list:** Summary table for all the I/O mappings and Data Converters within a specific recipe.

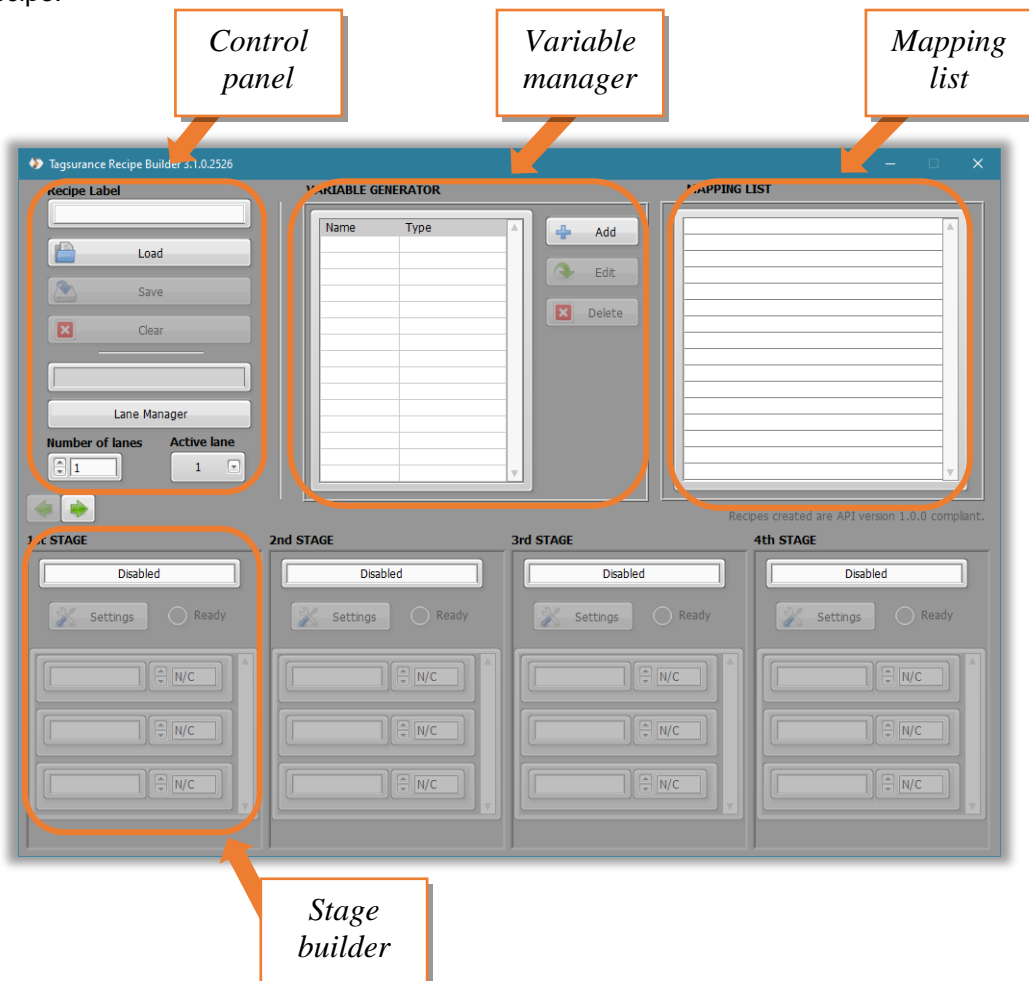

6.1.1 Recipe Builder installation

By default, Tagsurance Recipe Builder will be installed in C:\Tagsurance 3 folder.

Minimum system requirements for Tagsurance Recipe Builder:

- Windows 10 / 11
- Intel Core i3-7020U or better in CPU benchmark
- 8 GB RAM
- 1 GB free hard disk space
- Minimum screen resolution 1280 x 1024
- Mouse, keyboard

6.2 Add stations

A physical device of each station is defined in the stage builder section of Recipe Builder. The device type is selected from drop down menu, and then the device specific settings are available for task definitions.

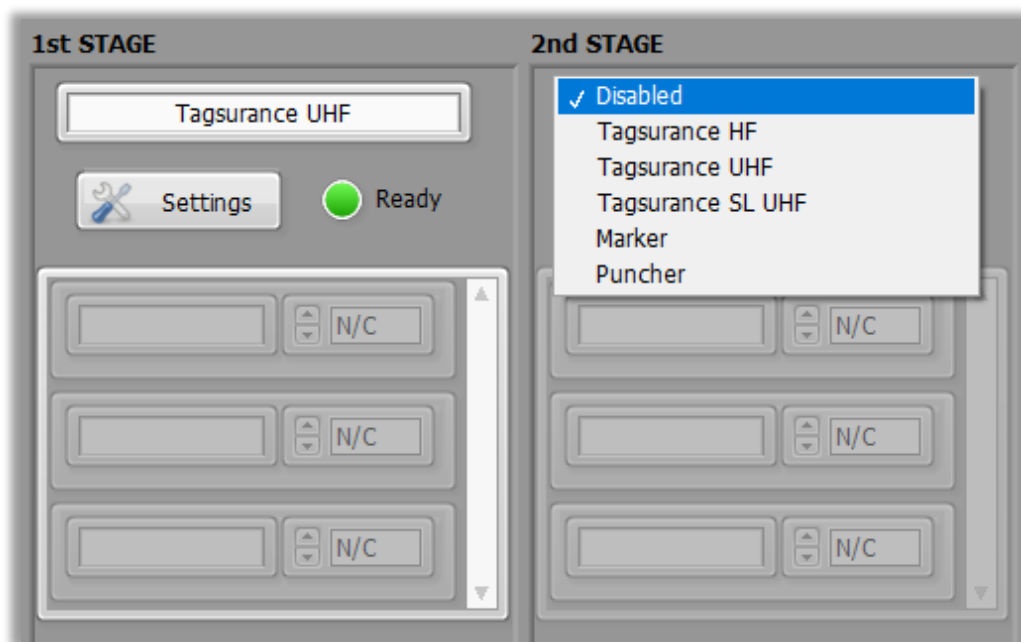

It is indicated whether the stage has all required settings defined or not. The recipe saving is possible only if the definitions of all stages are completed.

6.3 Define task lists for stations

6.3.1 Task list for Tagsurance UHF & Tagsurance SL UHF

Tagsurance UHF does active tests for UHF RFID tags. Each test is a task on the task list which will be performed for each tag. The primary result for a test is a grade of pass/fail, and test specific information may be included. The test specific information could be for example a sensitivity level or read memory content.

The selected protocol and timing settings are applied to all tasks on the task list. The supported test types depend on the selected protocol and vary between Tagsurance UHF and Tagsurance SL UHF.

The *Carrier Before Task (ms)* is the time how long the tester transmits RF power before it starts to modulate the command, i.e., the duration how long the RFID tag has time to get energized before the tester starts sending the first command. The default value for Tagsurance UHF and SL UHF is 1.5 ms. However, some RFID chip models require more, up to 3 ms, before they are fully functional.

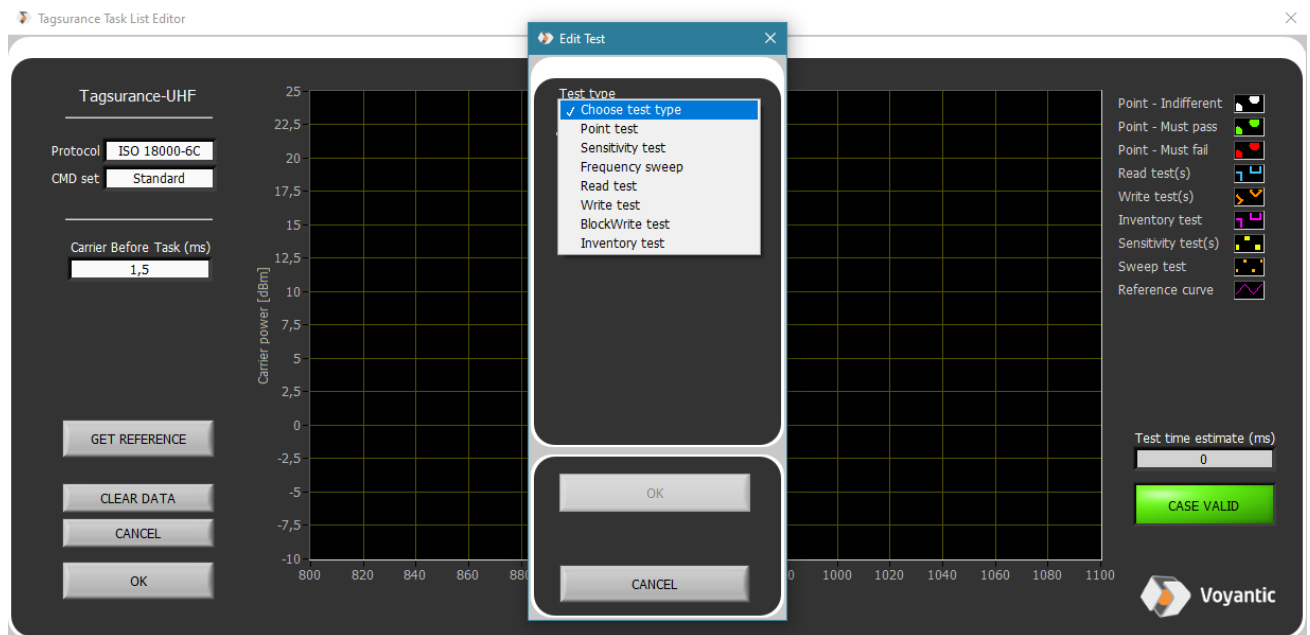

Add task for Tagsurance UHF

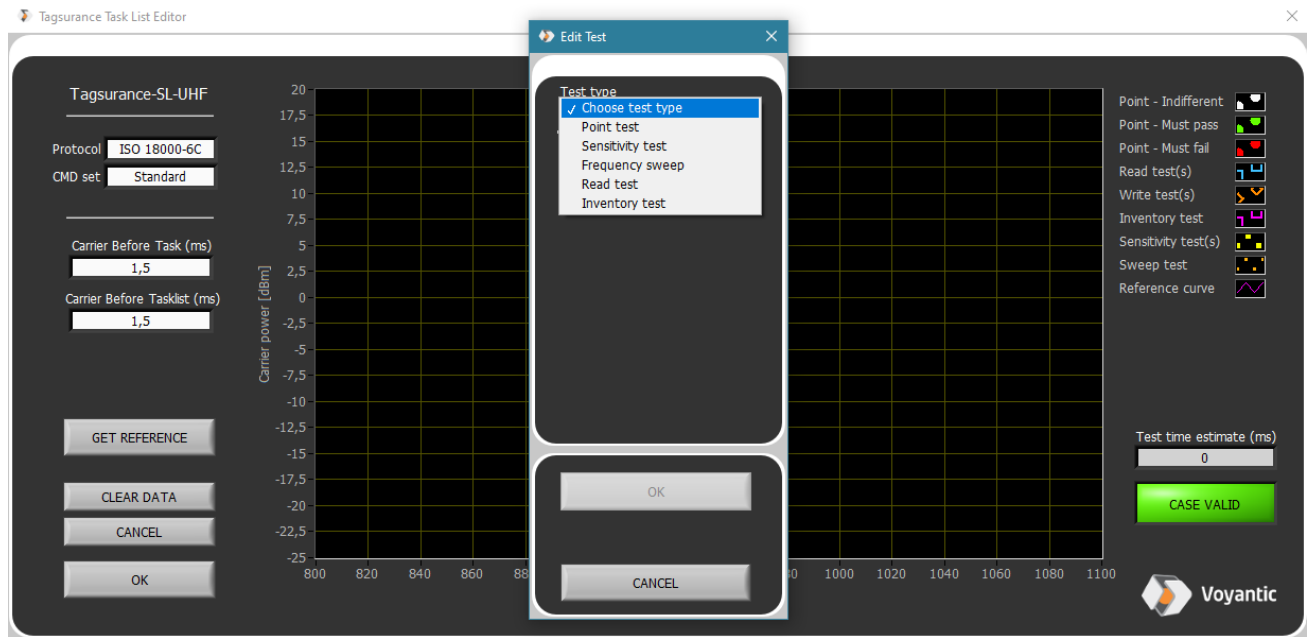

Add task for Tagsurance SL UHF

Tests can be added by mouse click on the graph. The added tests are shown in the graph. To edit or delete a single test, you can either double click or right click the test mark on the graph. The sensitivity test and frequency sweep must be clicked at the minimum end, power or frequency. **Clear Data** deletes all tests.

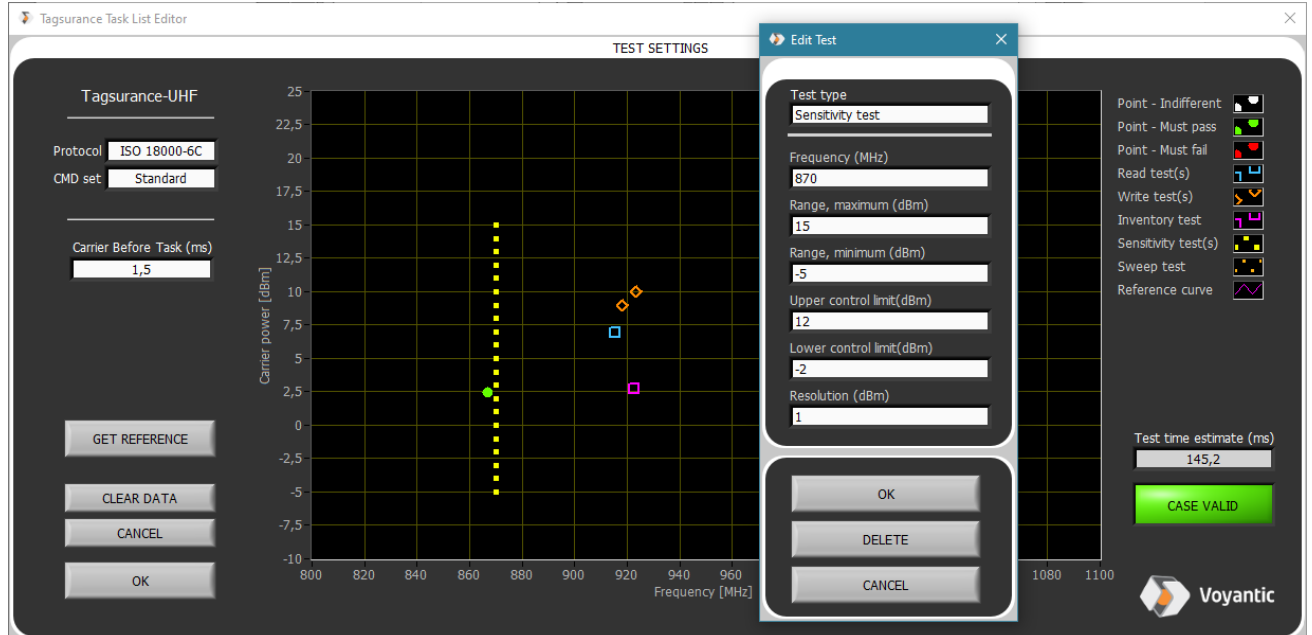

The test time estimation is updated after changes in the task list and is based on the task types and task settings. The time estimation for frequency sweep cannot be calculated.

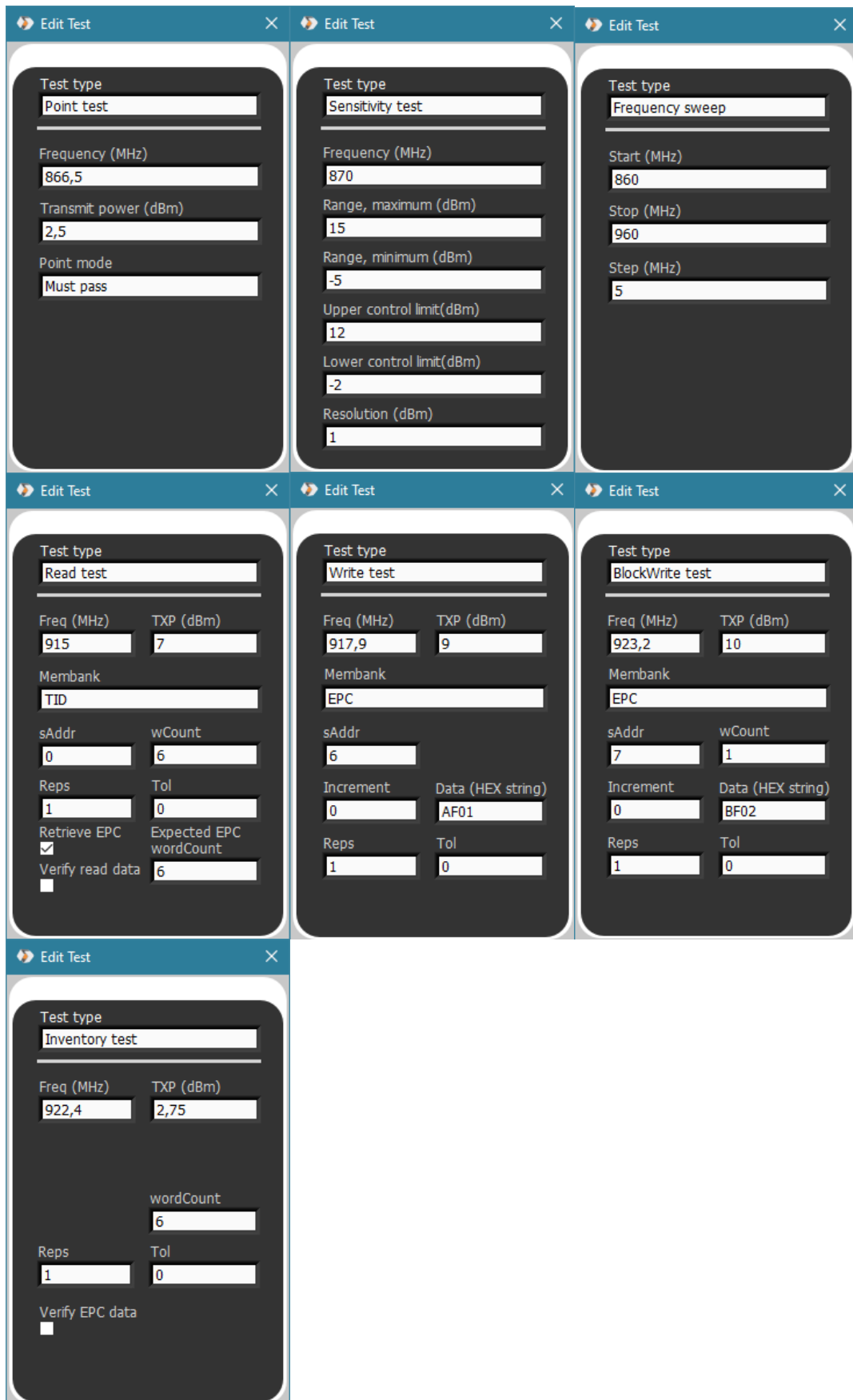

Test type	Test description	Test parameters
Point test	<p><u>Standard Point Test:</u></p> <p>A single command is transmitted, and it is detected whether tag replies or not.</p> <p><u>Enhanced Point Test:</u></p> <p>Before the standard point test command is transmitted, optional Select command can be sent.</p>	<p>Carrier transmit frequency (MHz)</p> <p>Carrier transmit power (dBm)</p> <p>Point mode:</p> <ul style="list-style-type: none"> - Must pass – the test is pass only if a tag replies - Must fail – the test is pass only if a tag do not reply - Indifferent – the test is always pass <p>Select (yes or no) optional:</p> <ul style="list-style-type: none"> • Used to verify that ICs that have a TID beginning with a standard GS1 or ISO header respond correctly to a Select command. Specifically, when set to true, tags with bit pattern 0b111000 stored in TID memory address 0 are instructed to set their S0 inventoried flag to B. Query used in the Point test will subsequently target tags that have followed the instruction.
Sensitivity test	Threshold power, the minimum transmit power to make a tag reply, at a single frequency is searched and it is detected if it is within control limits.	<p>Carrier transmit frequency (MHz)</p> <p>Range, maximum – Highest test power (dBm)</p> <p>Range, minimum – Lowest test power (dBm)</p> <p>Upper control limit – Highest accepted threshold power</p> <p>Lower control limit – Lowest accepted threshold power</p> <p>Resolution – The minimum difference on sensitivity level that can be detected. ¹⁾</p>
Frequency sweep	Threshold power across a frequency range is searched	<p>Start – Start frequency of the sweep (MHz)</p> <p>Stop – Stop frequency of the sweep (MHz)</p> <p>Step – Frequency step of the sweep (MHz)</p>
Read test	Memory bank read is performed and it is detected if read is successful or not	<p>Carrier transmit frequency (MHz)</p> <p>Carrier transmit power (dBm)</p> <p>Memory Bank – Reserved, EPC, TID or User</p> <p>Word pointer – the address of the first word to be read</p> <p>Word count – the number of words to be read</p> <p>Repetitions - Maximum number of test repetitions</p> <p>Tolerance - Maximum number of failed test repetitions allowed</p> <p>Retrieve EPC – Retrieve the EPC data from the Inventory sequence. Also the length of retrieved EPC has to be given.</p> <p>Verify read data – The read data can be verified with a data mask.</p>
Write test	Memory bank Write is performed and it is detected if the write is successful or not.	<p>Carrier transmit frequency (MHz)</p> <p>Carrier transmit power (dBm)</p> <p>Memory bank – Reserved, EPC, TID or User</p> <p>Word pointer – Address where the data is written to</p> <p>Data (HEX) – Data value to write</p> <p>Increment – The data value incrementation between tags</p> <p>Repetitions - Maximum number of test repetitions</p>

		Tolerance - Maximum number of failed test repetitions allowed
BlockWrite test	Memory bank write is performed by using EPC Gen2 BlockWrite command. It is detected if the write is successful or not.	Carrier transmit frequency (MHz) Carrier transmit power (dBm) Memory bank – Reserved, EPC, TID or User Word pointer – Address where the data is written to Word count – Number of words to be written Data (HEX) – Data value to write Increment – The data value incrementation between tags Repetitions - Maximum number of test repetitions Tolerance - Maximum number of failed test repetitions allowed
Inventory test	Perform a command sequence used for a tag inventory. It is detected if a tag is inventoried or not. In successful inventory the tag provides its EPC memory data.	Carrier transmit frequency (MHz) Carrier transmit power (dBm) Word count – the length of retrieved EPC data Repetitions - Maximum number of test repetitions Tolerance - Maximum number of failed test repetitions allowed Verify EPC data – The EPC can be verified with a data mask

- 1) The sensitivity test searches the threshold level by binary tree algorithm. The actual threshold level is within $Sensitivity_{result} \pm \frac{resolution}{2}$. The power range and resolution define the number of iterations is $N_{iterations} = \text{ceil}\left(\log_2\left(\frac{P_{high}-P_{low}}{resolution}\right)\right)$. The sensitivity result can be more precise than the resolution, e.g. the result can be 2.25 dBm even if the resolution is 1 dB.

6.3.2 Task list for Tagsurance HF

Tagsurance HF does active tests for HF RFID tags. Each test is a task on the task list which will be performed for each tag. The primary result for a test is a grade of pass/fail, and test specific information may be included. The test specific information could be for example a sensitivity level or read UID.

The selected protocol and timing settings are applied to all tasks on the task list. The supported test types depend on the selected protocol and command set.

The *Carrier Before Task [ms]* is the time how long the tester transmits RF power before it starts to modulate the command, i.e., the duration how long the RFID tag has time to get energized before the tester starts sending the first command. The default value for Tagsurance HF is 5 ms.

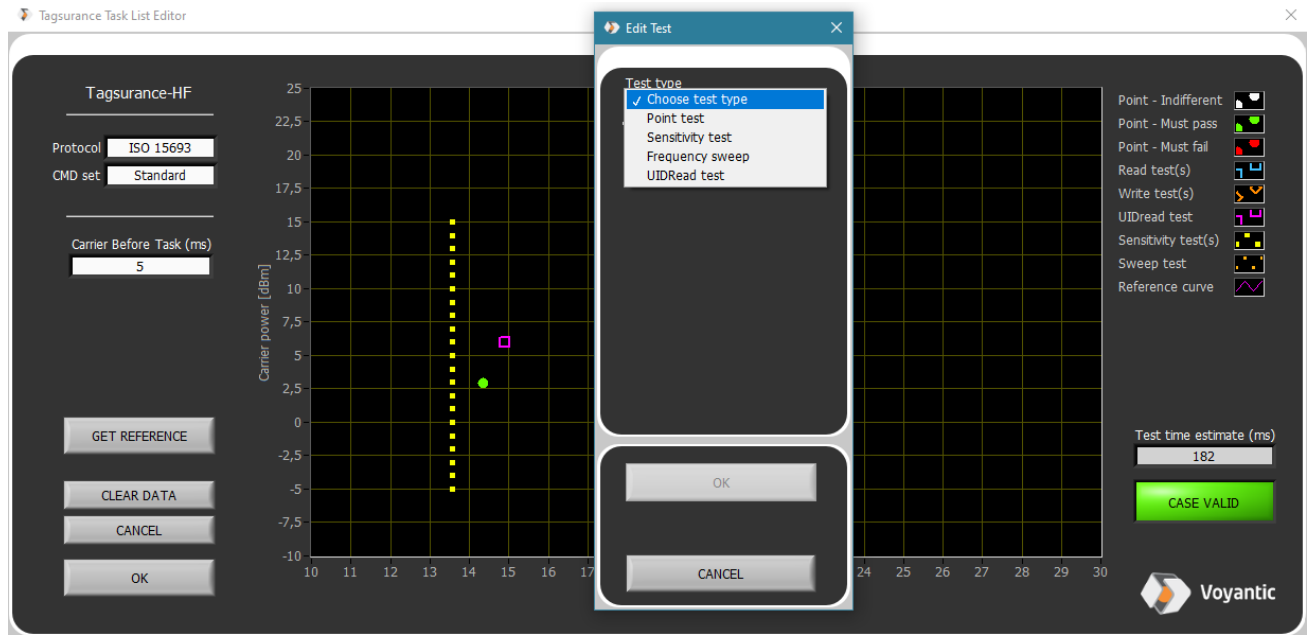

Add task for Tagsurance HF

Tests can be added by a mouse click on the graph. The added tests are shown in the graph. To edit or delete a single test, you can either double click or right click the test mark on the graph. The sensitivity test and frequency sweep must be clicked at the minimum end, power or frequency. **Clear Data** deletes all tests.

The test time estimation is updated after changes in the task list and is based on the task types and task settings. The time estimation for frequency sweep cannot be calculated.

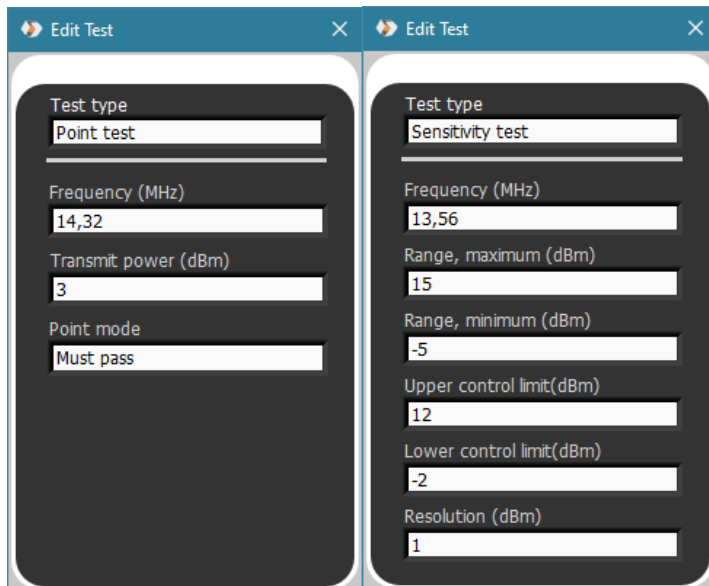

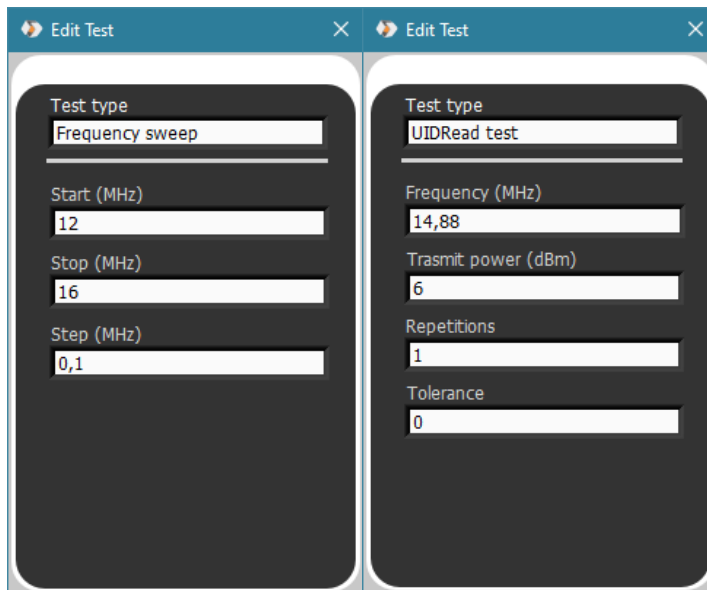

Test type	Test description	Test parameters
Point test	A single command is transmitted, and it is detected whether tag replies or not.	Carrier transmit frequency (MHz) Carrier transmit power (dBm) Point mode: - Must pass – the test is pass only if a tag replies - Must fail – the test is pass only if a tag do not reply - Indifferent – the test is always pass
Sensitivity test	Threshold power at a single frequency is searched and it is detected if it is within control limits	Carrier transmit frequency (MHz) Range, maximum – Highest test power (dBm) Range, minimum – Lowest test power (dBm) Upper control limit – Highest accepted threshold power Lower control limit – Lowest accepted threshold power Resolution – The minimum difference on sensitivity level that can be detected. ¹⁾
Frequency sweep	Threshold power across a frequency range is searched	Start – Start frequency of the sweep (MHz) Stop – Stop frequency of the sweep (MHz) Step – Frequency step of the sweep (MHz)
UID read test	UID memory read is performed and it is detected if read is successful or not	Carrier transmit frequency (MHz) Carrier transmit power (dBm) Repetitions - Maximum number of test repetitions Tolerance - Maximum number of failed test repetitions

- 1) The sensitivity test searches the threshold level by binary tree algorithm. The actual threshold level is within $Sensitivity_{result} \pm \frac{resolution}{2}$. The power range and resolution define the number of iterations is $N_{iterations} = \text{ceil}\left(\log_2\left(\frac{P_{high}-P_{low}}{resolution}\right)\right)$. The sensitivity result can be more precise than the resolution, e.g. the result can be 2.25 dBm even if the resolution is 1 dB.

6.4 Variables and mapping definitions

Variables are way to pass data into the process, for example from a file, and move data between stages. Because now the system supports stations for performance testing only, there is no use cases for variables. When Tagsurance 3 supports encoding, the variables and the variable mapping will be covered.

6.5 Example case of recipe building

The following example shows how to build a recipe for tag manufacturing process where

1. Tags are tested to make sure the quality is on expected level
2. Tags failed the quality requirements are visually marked
3. The chip of failed tags is punched, mechanically destroyed, to prevent them to work at all.

The simplest performance test is to test if a tag responds with the known reader transmit power. The end application may require the tags to work homogeneously so that the tags are not too sensitive.

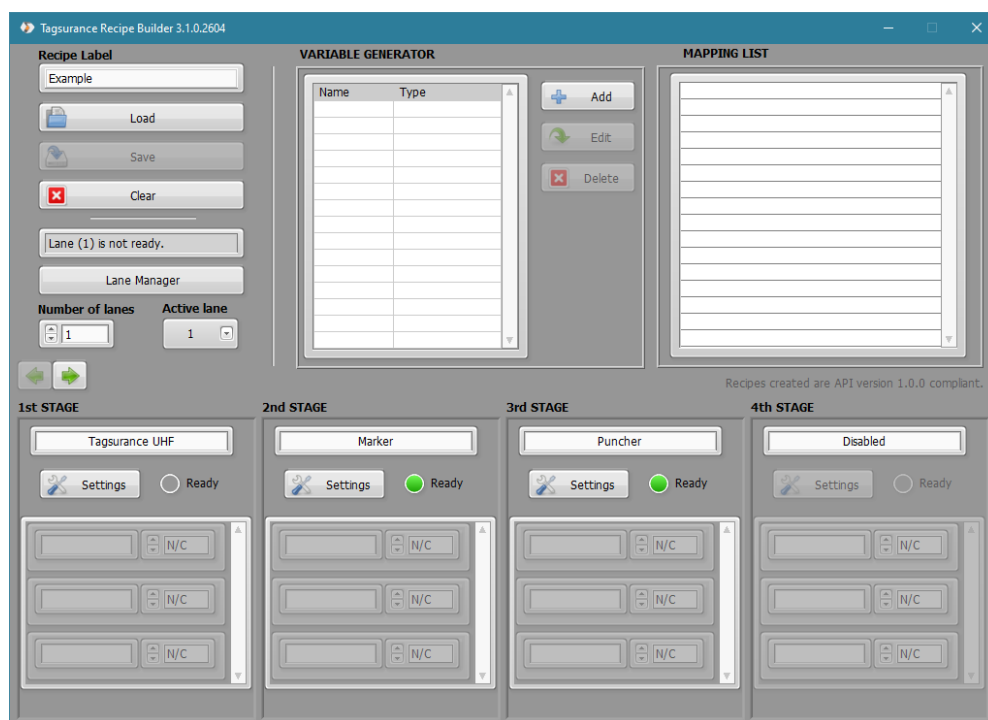

In Tagsurance Recipe Builder, you can start by giving a name for the recipe and choosing the device types for the stages as shown in the picture above.

In the Tagsurance UHF task list editor, you can measure a reference curve for the tags tested. First move a tag on the coupling element, to the position where tags will be when the test is done. Then, press the Get Reference.

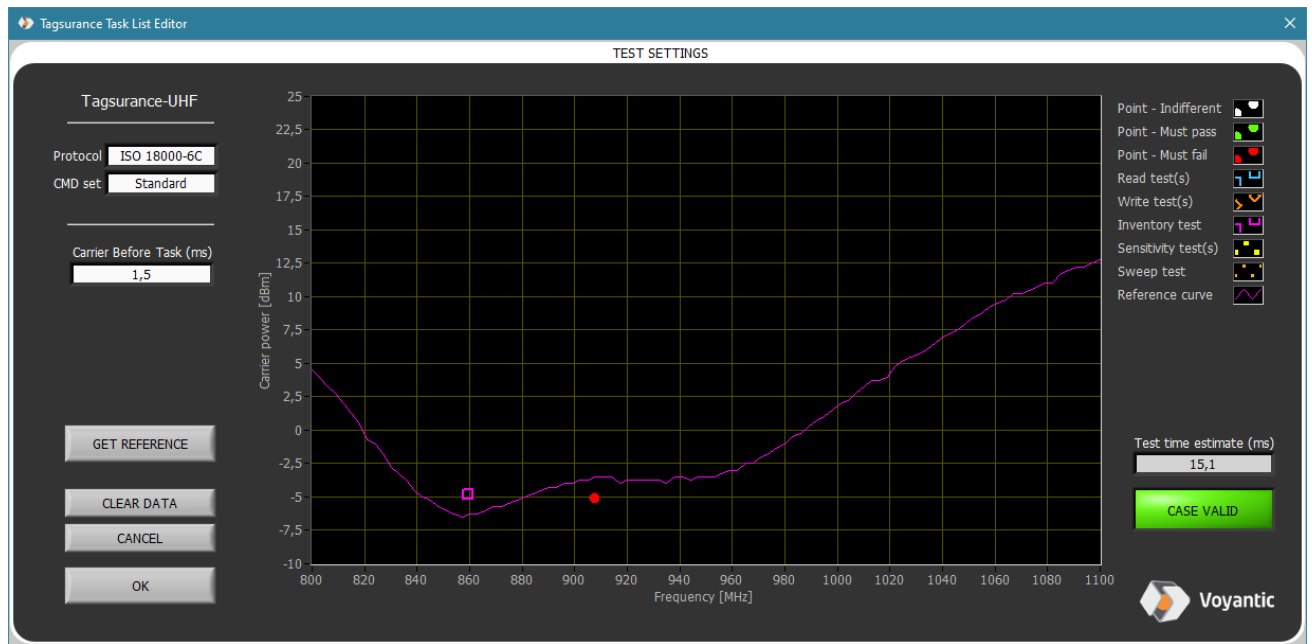

The reference curve shows the minimum transmit power level as a function of frequency the tag requires to be able to communicate. The tests are set so that tags with too high or too low sensitivity, or tags with shifted frequency tuning (the curve will shift in sideways) will fail.

The marker and the puncher are configured to mark and punch only the failed tags.

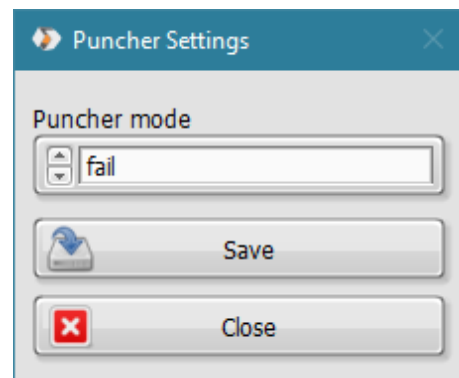
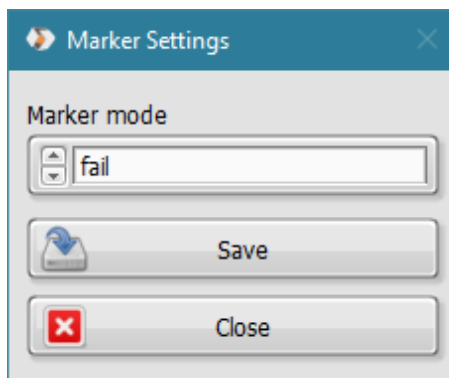

Now all stages are configured, and the recipe can be saved. Recipe Builder will generate a JSON file which is the recipe. The JSON structure is defined in *API* specification.

7 Running a job

Prerequisites:

- system installation has been done and all cables are correctly connected;
- a suitable lane configuration has been uploaded to the system;
- a suitable recipe has been created with *Recipe Builder*.

In the operator UI, first **Select Recipe** under **Job Configuration** and then **Start Job**. The job will run until you click **Stop Job**.

If there is any error in starting the job, it is indicated in the errors section in the operator UI.

After a job is completed, you can download the results and the used job data (recipe and other settings) by clicking **Export Data**.

The maximum job size is 100M results.

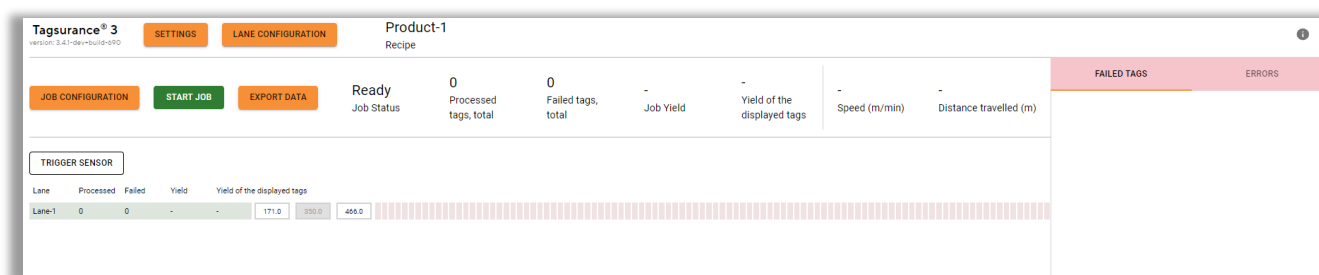

7.1 Updating a lane configuration

In the operator UI, when you open Lane Configurator, it will show you the current lane configuration stored in Tagsurance Controller.

You can modify the existing lane configuration or replace it by importing another configuration from a JSON file. You may have formerly exported the JSON file from the operator UI to your default downloads location or created it using the older version of Lane Configurator.

Note: To save your changes in Tagsurance Controller, click **Save**.

The system will store the lane configuration until a new one is loaded. There is no need to load/update lane configuration after system restart, but rather only after mechanical changes in the system setup, such as the trigger or coupling element position, device order, device count, etc.

You can also edit the machine IO part of the lane configuration in the operator UI. Note that if you edit it in the operator UI and then load a lane configuration, the changes made in the operator UI will be overridden.

The lanes and devices of the loaded lane configuration are illustrated in the operator UI. The white boxes with *distanceFromTrigger* values represent stations. The distance from trigger values can be fine-tuned to adjust the tag position on the coupling element at the time the station is triggered.

7.2 Selecting a recipe

In the operator UI, click **Job Configuration** and on the **Recipe tab** of the modal that opens, **browse the JSON file that is the recipe** you want to use. The name of the button name depends on whether you already have or have not chosen a recipe. In case the recipe selection button is disabled, you must load the lane configuration first. When you have selected the recipe, the job is ready to be started.

7.3 Job configuration

7.3.1 Job type selection

The job type defines the principle of how Tagsurance 3 system works. A standard job is agile and works in most cases. In addition to the standard job, there are machine model specific job types.

7.3.1.1 Standard job

The standard job is for most of the use cases. The standard job is for single lane and multi lane machines, and it supports all the features Tagsurance 3 system has.

7.3.1.2 TAL15k job

Tagsurance 3 system can be used with Mühlbauer TAL15k machine. Tagsurance 3 supports the “RS232 tester interface” of TAL15k machine, and the system works seamlessly as a part of machine. Due to the special use case, there are limitations and requirements for Tagsurance 3 configuration.

- Only three device types are supported for stations controlled by Tagsurance 3
 - Tagsurance SL UHF
 - Tagsurance HF
 - IO only device
- Lane controller version 1.1 is required because of the 25-pin machine IO connector and its dedicated pins for RS232 communication.
- Regardless of the number of lanes, only one lane controller is in use and all devices, one or two, are connected to it.
- In the case of two devices, both must be the same type.
- The recipe must be made for a single lane and single device. The same recipe will be assigned to both devices.
- Tagsurance 3 does not control the bad tag marking but TAL15k does that.

- The test matrix size must be configured the same in Tagsurance 3 job configuration and in TAL15k machine settings.
- TAL15k machine must have the “RS-232 tester interface” enabled.

The screenshot shows the 'Job configuration' window with three tabs: 'Recipe', 'Lot', and 'Trigger settings'. The 'Recipe' tab is selected. It contains the following elements:

- Job Label:** A text input field containing 'job'.
- Job type:** Three radio buttons: 'Standard' (unselected), 'TAL15K (serial interface)' (selected), and 'DDA (serial interface)' (unselected).
- Test matrix size:** Two input fields: 'Rows' with '4' and 'Columns' with '10', separated by an 'X' symbol. A grey 'Test matrix' button is to the right.
- Device mapping:** Two dropdown menus for 'Tester 1' and 'Tester 2', both showing 'Tagsurance SL UHF 1_1 - Tag...' and 'Tagsurance SL UHF 1_2 - Tag...' respectively.
- Bottom:** A 'Recipe' label, 'UHF testing' text, and an orange 'BROWSE...' button.

When a job is running, the results are shown real-time in Tagsurance 3 operator UI, and the result details are available as they are in a standard job. Tagsurance 3 provides the pass/fail information of the results to TAL15k machine as well and the machine HMI shows the results normally.

The screenshot shows the operator UI with a 'Running' job status. It includes summary statistics for the job and Lot 2, and a detailed table of results for four lanes with a corresponding bar chart.

Job		Processed	104	Good	96	Not counted	4
Yield		92.31%	Bad	8	Not tested	4	
Lot 2		Processed	4	Good	3	Not counted	0
Yield		75.00%	Bad	1	Not tested	0	

Lane	Processed	Good	Bad	Not counted	Not tested	Lot yield
Lane 1	26	25	1	0	2	0.00%
Lane 2	26	22	4	0	2	0.00%
Lane 3	26	26	0	2	0	0.00%
Lane 4	26	23	3	2	0	0.00%

Tags can be retested as long as they are located in the test matrix area. When the tag exits from the test matrix area, the tag result is finalized and published. In TAL15k job, the column of tags is handled as a unit which must be complete to get counted into a lot or yield calculation. If one tag in a column is not tested, the statuses of other results in the same column are changed to NOT_COUNTED. When the job is stopped, all the results are finalized, and tag results are published even if the tags are on the test matrix.

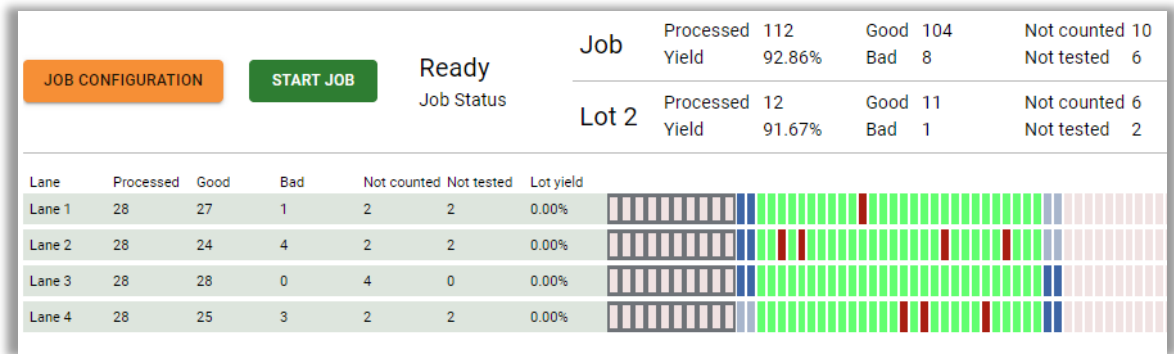

7.3.1.3 DDA job

Tagsurance 3 system can be used with Mühlbauer DDA machines which supports “RS232 tester interface”, e.g., DDA40k. Tagsurance 3 supports the “RS232 tester interface” of DDA machine, and the system works seamlessly as a part of machine. Due to the special use case, there are limitations and requirements for Tagsurance 3 configuration.

- Only three device types are supported for stations controlled by Tagsurance 3
 - Tagsurance SL UHF
 - Tagsurance HF
 - IO only device
- Lane controller version 1.1 is required because of the 25-pin machine IO connector and its dedicated pins for RS232 communication.
- One lane controller is in use and all devices, one or two, are connected to it.
- In the case of two devices, both must be the same type.
- The recipe must be made for a single lane and single device. The same recipe will be assigned to both devices.
- Tagsurance 3 does not control the bad tag marking, but DDA does that.
- The mechanical setup, the distance between coupling elements, must be configured the same in Tagsurance 3 job configuration and in DDA machine settings.
- DDA machine must have the “RS-232 tester interface” enabled.

Job configuration

Recipe Lot

Job Label

Job type Standard
 TAL15K (serial interface)
 DDA (serial interface)

Distance between stations Tags

Device mapping

Tester 1 ▼

Tester 2 ▼

Recipe UHF testing

When a job is running, the results are shown real-time in Tagsurance 3 operator UI, and the result details are available as they are in a standard job. Tagsurance 3 provides the pass/fail information of the results to DDA machine as well and the machine HMI shows the results normally.

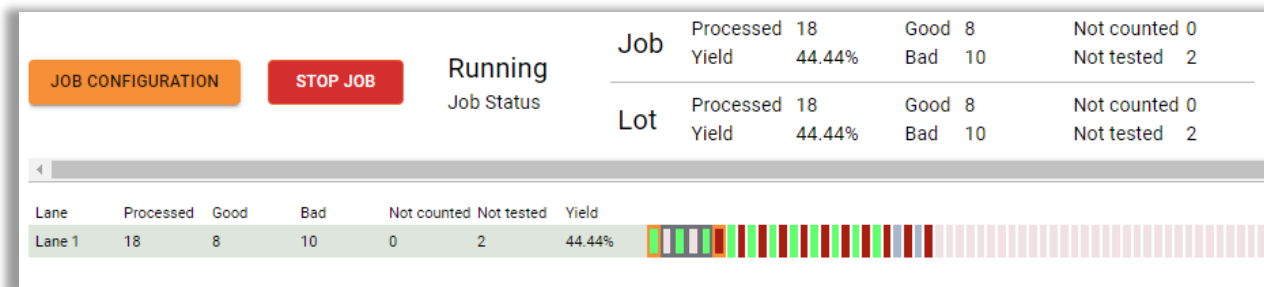

A second tester can retest a tag that the first tester has already tested. When the tag passes the last tester, the tag result is finalized and released. If no tester has tested the tag, the status of the tag result is UNTESTED. When the job is stopped, all tag results are finalized, and tag results are published even if the tags have not passed the last tester.

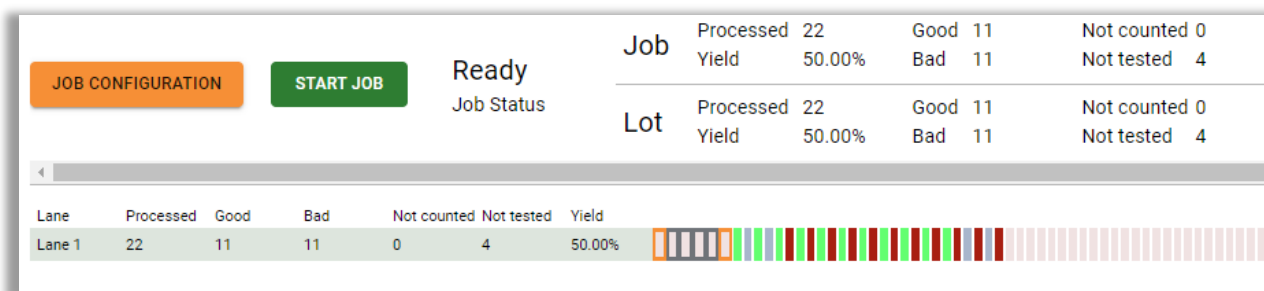

7.3.1.4 API trigger job

The API trigger job is like the standard job, but with a limited feature set supported and with a different trigger source. When an API trigger job is running, the stations can be triggered by sending an API trigger request to the REST API. The received API trigger request causes the lane controller to trigger the defined device by IO signal. The IO signal interface of devices is the same regardless of the job type.

The results from API triggered devices are available only in the AsyncAPI channel *tag-event*. The *Station Result* is streamed out when the result is ready, and there is no way to retrieve the result afterwards – the data export is not supported. The possible errors in triggering, e.g. the requested device is not active in the running job, are indicated as messages in the AsyncAPI channel *error-messages*. Refer to API documentations, see the section 10.5 .

Compared to the standard job, there are restrictions in the API trigger job. Anything related to yield calculation, lot management, trigger detection (trigger sensor), and action triggers are not supported. This is simply an API trigger request followed by the streamed station result. The API trigger request is rejected when any other job type is in use. The API trigger is available only in the API, and there is no implementation for this in the operator UI.

The latency in triggering a device by an API trigger is not deterministic due to network and operating system processes. This is why the API trigger is not a feature for moving material but can only be used in stop-and-go processes, or to verify the stations are working as expected before starting the production process. The magnitude of the latency is tens of milliseconds, and there is no more precise promise about its duration.

7.3.2 Trigger settings

The lane controller can be set up to use trigger filtering, which can be useful when dealing with tags/materials from which a single trigger per item is difficult to achieve.

Filtering can be achieved by hold-off distance with the edge trigger or by using the pattern trigger. It is also possible to use hold-off distance with the pattern trigger but usually it is not necessary. The hold-off distance has its risks especially with the edge trigger. If, for any reason, the correct edge is missed and an edge normally filtered away with hold-off is then hit, the system is stuck with an incorrect trigger position.

The screenshot shows the 'Job configuration' window with the 'Trigger settings' tab selected. The configuration includes:

- Pitch:** 36 mm
- Hold off:** 10 mm
- Simulate trigger when past pitch:** 3 mm
- Trigger type:** Edge (dropdown menu)

A warning message is displayed below the 'Hold off' field:

Please use carefully, especially with edge trigger if tag has multiple edges and first one is missed, with certain holdOff values the trigger point may not recover to the correct one

7.3.2.1 Trigger type – edge

Edge is a very simple solution where any rising edge in the trigger signal is detected as a trigger and treated as a tag leading edge (given that the distance from the trigger on stations is set to the leading edge of a tag).

7.3.2.2 Trigger type – pattern

A pattern can be specified so that it must be matched before a trigger is accepted. The trigger point does not need to be the beginning of the pattern.

It is usually advisable to keep the pattern the simplest unique pattern found in the tag.

The maximum pattern length is 30 mm, and it can contain up to 10 areas.

The resolution for areas in a pattern is 0.2 mm.

Acceptance ratio is calculated as the correlation of the received trigger signal and the defined pattern.

Try to come up with patterns that have relatively similar amounts of ACTIVE and PASSIVE areas, and be careful with patterns that have, for example, only 0.2 ratio of ACTIVE compared to PASSIVE (or vice versa), as the acceptance ratio works over the whole pattern. For example, having an acceptance ratio of 0.9 combined with PASSIVE/ACTIVE ratio of 0.9 would mean that no signal (PASSIVE) from the trigger for pattern length would be interpreted as a trigger.

For more details about the pattern trigger, see the Appendix: How to Configure the Pattern Trigger.

7.3.2.3 Hold-off distance

See the following example of such a use case. The tags have such a design that without filtering the trigger sensor would react multiple times to each tag, resulting in unwanted triggers.

The settable multi-trigger filter *holdOffDistance* can be configured so that only the first edge of the tag would be detected, and so that the remaining edges are ignored for the remainder of the tag (see the red-striped sections in the example).

After the accepted trigger pulse, the multi-trigger filter ignores the signals from the trigger sensor at the *holdOffDistance* travel.

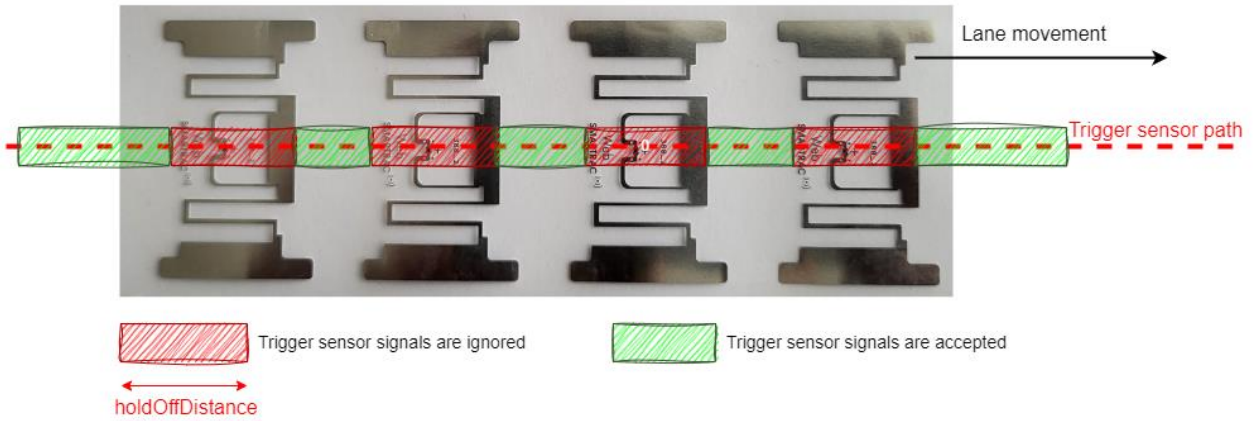

Warning!

The hold-off distance must be used carefully. Do not use longer hold-off distances than necessary. Especially with simulated trigger, there is a high risk the triggering gets completely off. Then tags are triggered at wrong location by the simulated triggers and the system may not recover to detect the tags correctly according to the trigger sensor. See sections 11.4 and 11.5.

7.3.2.4 Simulated trigger

In case a tag is not triggered because of missing tag or sensor fails the detection, the *missingTrigger behavior* can be applied. Tagsurance 3 can simulate the trigger as if a tag had been normally detected.

After the previous trigger position, the following trigger will be simulated when the lane has travelled the distance of $pitchMm + simulateTriggerWhenPastPitchMm$ without receiving the trigger signal from the sensor. The simulated trigger is placed on a pitch after the previous trigger position. It doesn't matter if the previous trigger is simulated or based on sensor detection. The trigger simulation is based on the *Pitch* and the *Simulate trigger when pass pitch* values defined in the job configuration.

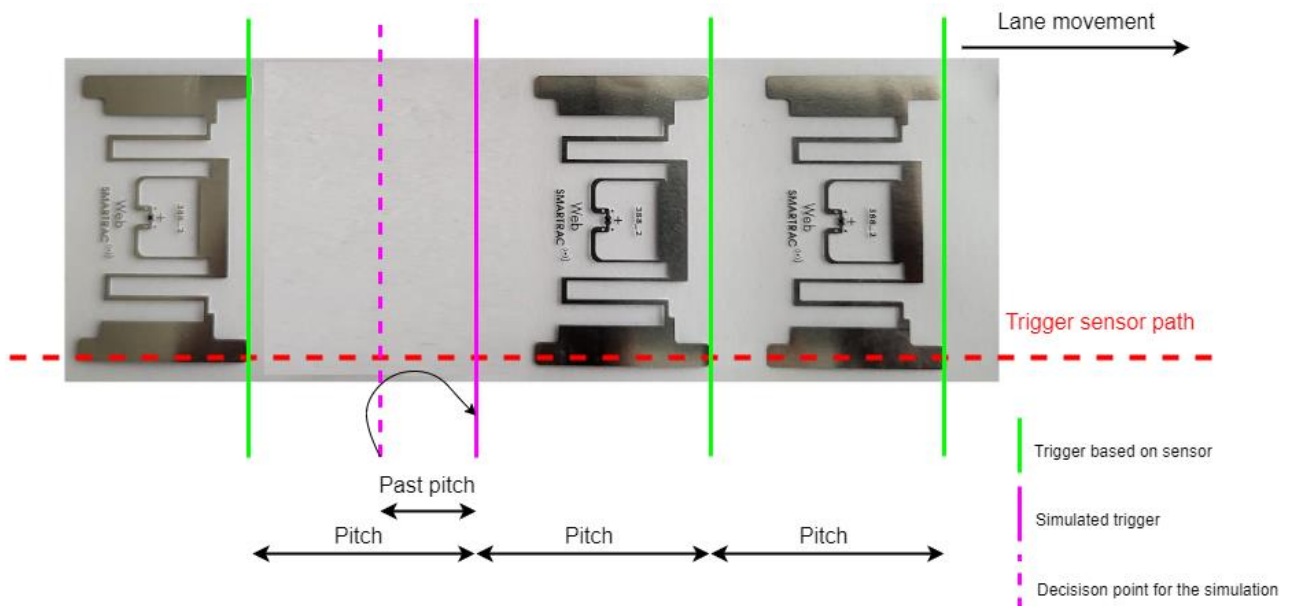

The first trigger cannot be simulated, but once the first tag is detected by the sensor the following triggers can be simulated. Once the simulation prerequisites are full filled, all the following triggers can be simulated even if the sensor is not even connected any more.

Warning!

When the pattern trigger is defined, the *simulateTriggerWhenPastPitchMm* value must be greater than the length of the pattern, and some extra. The entire pattern of the tag features must be recognized completely before the trigger is applied based on the pattern. If the trigger is simulated before the pattern is recognized, an extra trigger is generated, and the tag will be triggered twice. See the section 11.4.

7.3.2.5 Pitch

The pitch of the tags on material means the repetition rate in the distance between the tags. It is given at the tenth of a millimeter resolution, e.g., 23.6 mm.

7.3.3 Lot settings

Tags can be marked as a lot in the in results based on the lot settings. The lot change can be managed by the Tagsurance 3 system when the lot change is done after the defined number of tags are processed. When Tagsurance 3 is counting tags for a lot, the lot change position can be indicated to a machine by an IO signal.

The lot change can also be controlled by the external source, for example the machine can give a signal to Tagsurance 3 system when the current lot is completed, and a new lot begins. In this mode some of the Tagsurance 3 features are disabled.

7.3.3.1 Lot control by Tagsurance 3 system

The lot counter in Tagsurance 3 system can mind all/passed tags over all lanes or require a minimum number on all lanes. The lot fulfilment will not stop the job. Instead, the counter will reset, the lot number will increase, a new lot will begin, and the job keeps running uninterrupted.

The status of the lot completion can be used as a trigger for output signals in a machine IO connector.

In the exported results and in API the lot is called batch. Only the name is different.

The maximum number of lots in a job is 5000. The maximum lot size is not limited but the job size is, see the Section 7 Running a job.

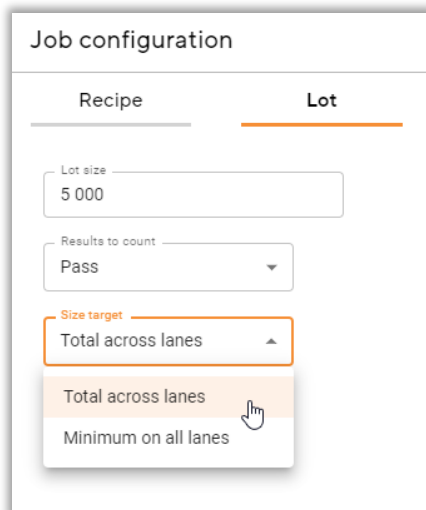

7.3.3.2 External lot change control

When the external lot change control is enabled, Tagsurance 3 system does not make decisions when a lot is completed but the lot change happens only when the system receives a signal from the machine. For example, a turret rewinder can make decisions when the lot must be changed.

To enable the external lot change control, you must

- define the lot change location in lane configuration
- define the input pin of the machine IO connector in lane configuration
- enable the external lot control in job configuration

The lot change location must be after the stations, i.e. the distance from trigger must be greater than the stations have. See the requirement in Section 10.4 Station locations. Lane controller version 1.x is the hardware requirement for the external lot change. See the input pins in Section 10.1.5.1 Machine IO connector in Lane controller 1.X .

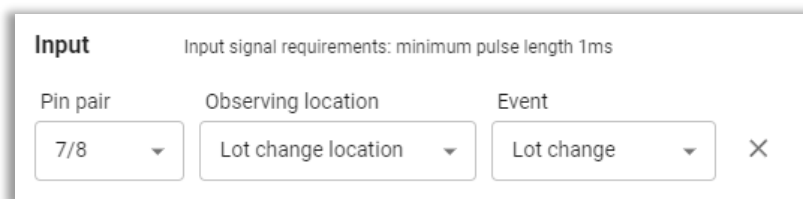

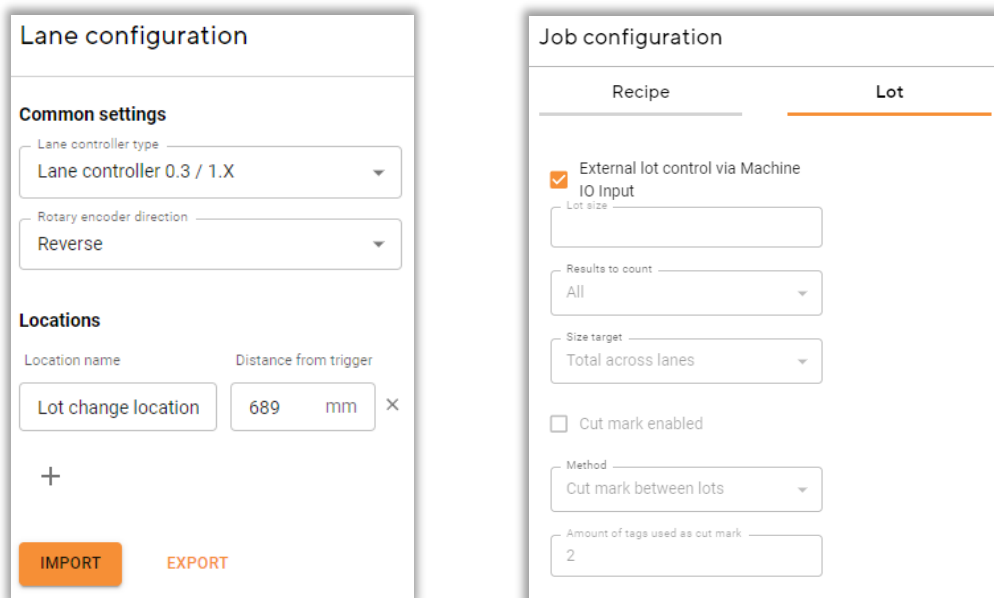

When the external lot control is enabled, the cut mark and the lot completion action triggers are not applicable. The external lot control is not supported in TAL15k and DDA (serial interface) job types.

7.3.4 Cut mark

The cut mark is a defined number of marked tags between the lots. This makes it easier to differentiate the lots from each other. The cut mark feature uses the markers to mark tags and the results of these marked tags are not counted to lots or yields, and the status of results is changed to be NOT_COUNTED.

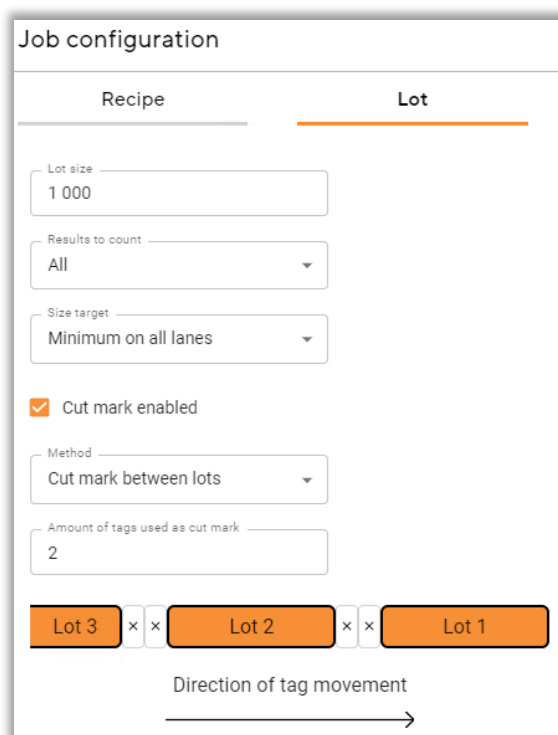

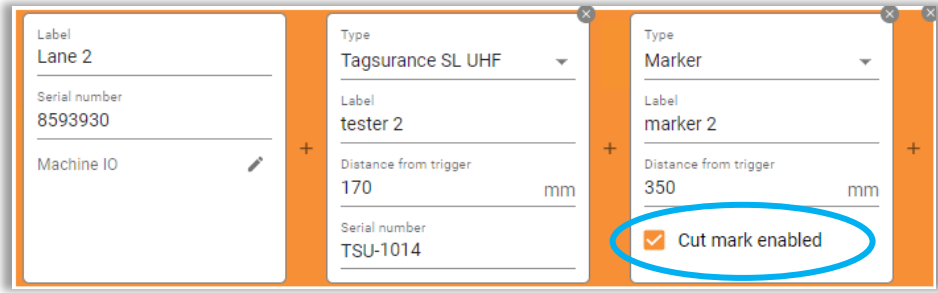

Any marker in the lane configuration on active lane can be used for the cut mark, and at least one marker must be selected for this purpose if cut mark is enabled. In addition to the cut mark marking, the selected markers work as defined by the recipe. If a marker should be used only for cut mark marking, omit it in the recipe. In a multilane setup, the tags do not need to be marked on each lane. However, in the column where the cut mark is made to at least one tag, the status of all tag results is changed to NOT_COUNTED. This can be seen in the operator UI.

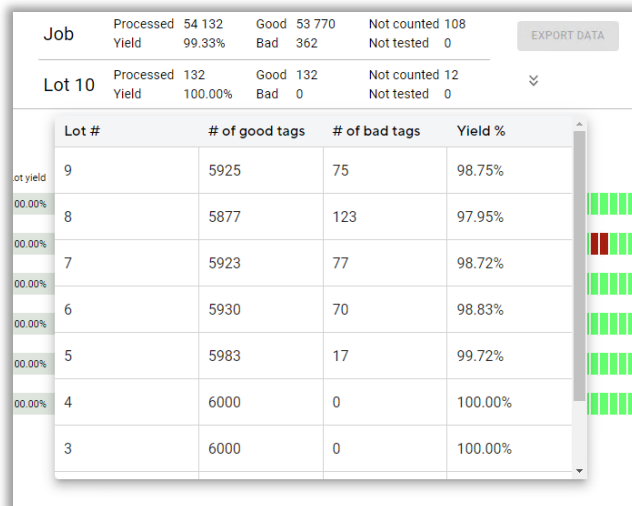
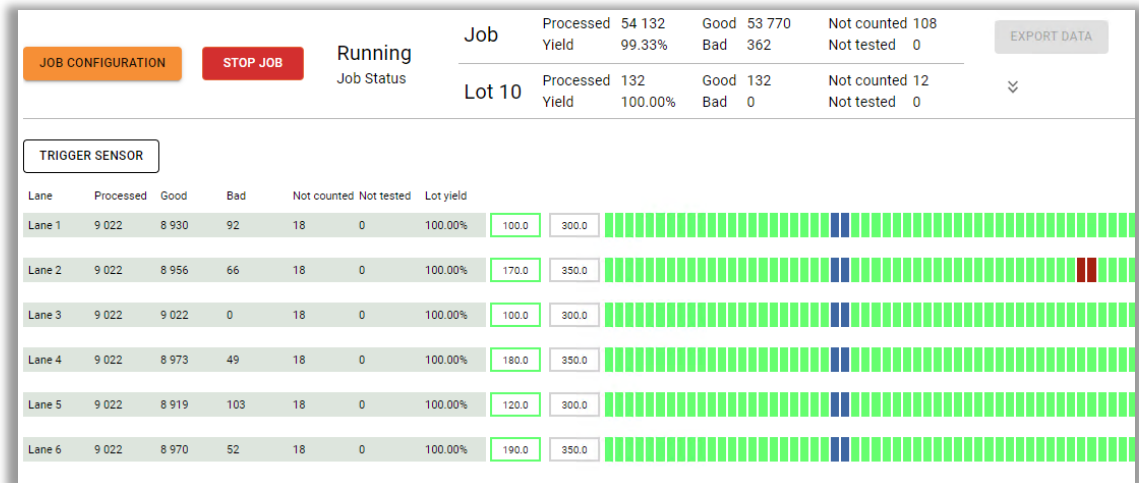

7.3.5 Action trigger

The machine IO output signals are configured by:

- actions –changes in the signal state
- action triggers – when the action takes place

To define an action trigger:

1. Select the action trigger type.
2. Define the type specific properties.
3. Select the actions to be triggered.

The actions defined in a lane configuration are automatically available here in the action trigger settings.

Example configuration:

- After a job is started and the system status has changed to *Running*, the action *Job running* is triggered;
- When a job stops, and the system status turns to *Stopping*, the actions *Job stopped* and *Stop machine* are triggered;
- When a lot is almost full, the action *Slow down* is triggered;
- When the lot is full and the last tag of the lot is at the position of Splicing table, the actions *Stop machine* and *Speed up* are triggered.

Recipe	Lot	Trigger settings	Action triggers
Type: Status change	Target status: Running	Action: Job running	Select action
Type: Status change	Target status: Stopping	Action: Job stopped	Action: Stop machine
Type: Lot completion	Amount before: 20 pcs	Observing location: Cutting table	Action: Slow down
Type: Lot completion	Amount before: 0 pcs	Observing location: Cutting table	Action: Stop machine
Type: Yield	Scope: Lot	Yield type: Per lane	Window size: Not set
		Trigger when yield below: 99.50 %	Action: Stop machine

The actions and locations are defined in a lane configuration described in Section 5 *Building lane configuration*. For information on defining machine IO settings, see section 5.1.1 and section 10.1.5 for Machine IO connector.

7.4 Results

7.4.1 Results in operator UI

Results are shown in operator UI for each tag on the tag result level but also more detailed on the station result level. The statuses of results are shown in colors:

- PASS – green
- FAIL – red
- ERROR – orange
- NOT_COUNTED – blue
- UNTESTED – grey

In addition to the overall tag results, you can also view more detailed station and even task specific results by clicking the station. You can investigate the details of failed tag results on the right.



The station results are also visualized in other views: *Tag graph*, *Task list*.

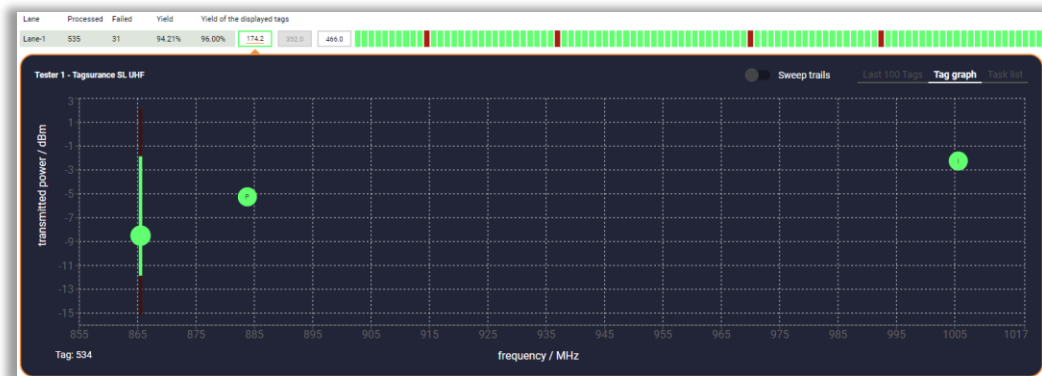

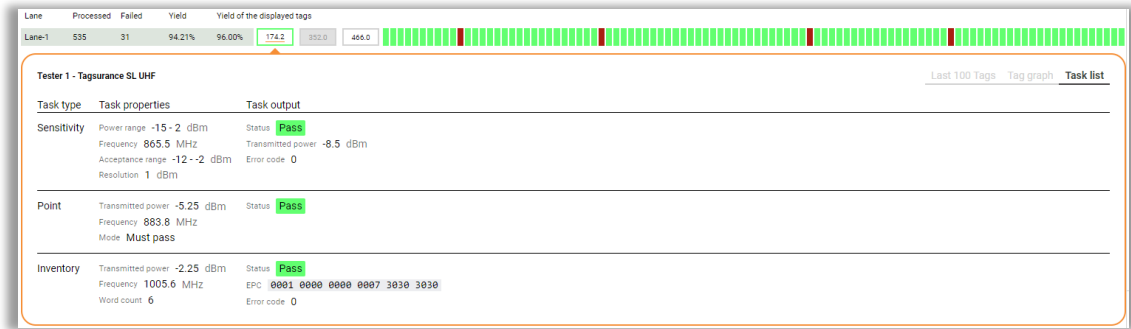

More detailed results of a failed tag can be reviewed by selecting the *Station* under the *Tag Info*.

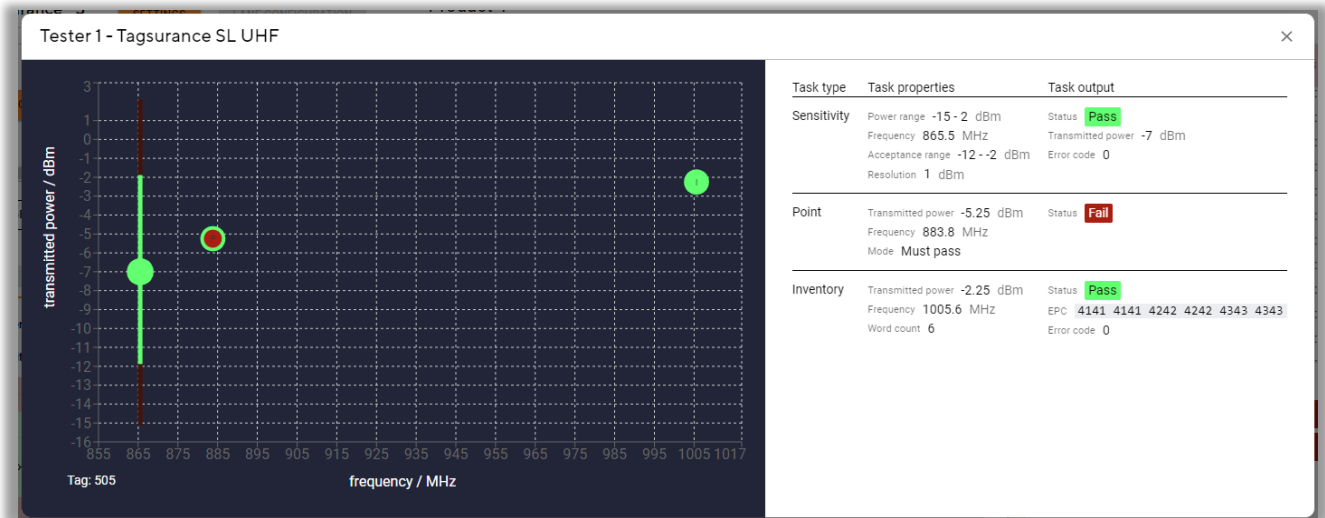

Errors in tag results are shown in the list of *failed tags* highlighted with orange. The errors leading to this are listed in Section 7.4.4.3 *Station result errors*.

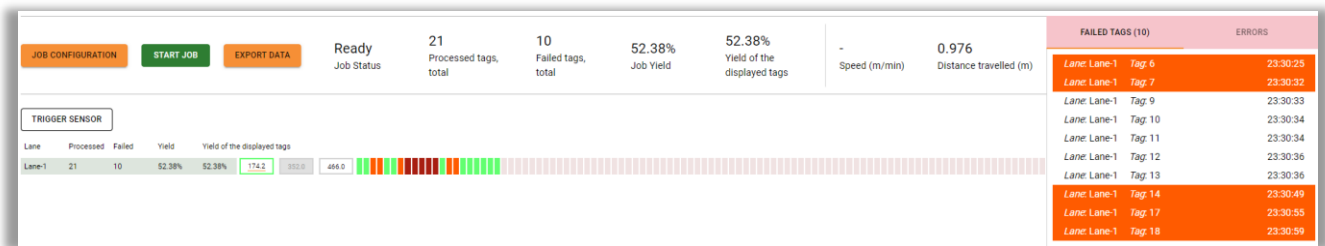

7.4.2 Result saving

The results can be saved by exporting the result data from operator UI. The result data is packed into a zip file which will be downloaded and saved to the default download folder of the computer where the operator UI is running. The saving location is the browser's default downloading location. The result downloading is possible when the system is in idle state and a job is not running.

Job	Processed	122	Good	106	Not counted	0	EXPORT DATA
	Yield	86.89%	Bad	16	Not tested	0	
Lot 6	Processed	4	Good	3	Not counted	0	⌵
	Yield	75.00%	Bad	1	Not tested	0	

Lot #	# of good tags	# of bad tags	Yield %
6	3	1	75.00%
5	21	1	95.45%
4	20	10	66.67%
3	21	1	95.45%
2	21	1	95.45%
1	20	2	90.91%

The content of the exported result data packages is as follows.

- Job results
 - job summary (.csv)
 - job configuration (.json)
 - the tag results in lane specific files (.csv)
- Lot results
 - job configuration(.json)
 - the tag results of a lot in one file (.csv)

The CSV files have a header row before the data, and separator is comma (.). The job configuration files are formatted according to the API specification. The result files can be opened, and data viewed in any suitable csv viewer. For example, the results can be imported to MS Excel.

Column3	Column4	Column5	Column6	Column7	Column8	Column9	Column10	Column11	Co
Lane Label	Tag Number	Result Number	Timestamp	Tag Result	Batch ID	Job ID	Job Label	Station 1 / Stage 1 TSU / Task 1 POINT / status	Sta
76ff Lane 1	48	98	2023-06-30T16:27:48.982279Z	PASS	5	08297c22-eac9-4857-987f-ec10be4ce121	job	PASS	PA
76ff Lane 1	49	100	2023-06-30T16:27:49.259286Z	PASS	5	08297c22-eac9-4857-987f-ec10be4ce121	job	PASS	PA
76ff Lane 1	50	102	2023-06-30T16:27:49.528985Z	FAIL	5	08297c22-eac9-4857-987f-ec10be4ce121	job	FAIL	FA
76ff Lane 1	51	104	2023-06-30T16:27:49.759208Z	PASS	5	08297c22-eac9-4857-987f-ec10be4ce121	job	PASS	PA
76ff Lane 1	52	106	2023-06-30T16:27:50.018531Z	PASS	5	08297c22-eac9-4857-987f-ec10be4ce121	job	PASS	PA
76ff Lane 1	53	108	2023-06-30T16:27:51.900793Z	PASS	5	08297c22-eac9-4857-987f-ec10be4ce121	job	PASS	PA
76ff Lane 1	54	110	2023-06-30T16:27:52.404456Z	PASS	5	08297c22-eac9-4857-987f-ec10be4ce121	job	PASS	PA
76ff Lane 1	55	112	2023-06-30T16:27:52.795324Z	PASS	5	08297c22-eac9-4857-987f-ec10be4ce121	job	PASS	PA
76ff Lane 1	56	114	2023-06-30T16:27:53.103007Z	PASS	5	08297c22-eac9-4857-987f-ec10be4ce121	job	PASS	PA
76ff Lane 1	57	116	2023-06-30T16:27:53.386744Z	PASS	5	08297c22-eac9-4857-987f-ec10be4ce121	job	PASS	PA
76ff Lane 1	58	118	2023-06-30T16:27:53.668457Z	PASS	5	08297c22-eac9-4857-987f-ec10be4ce121	job	PASS	PA
33927 Lane 2	48	97	2023-06-30T16:27:48.933198Z	PASS	5	08297c22-eac9-4857-987f-ec10be4ce121	job	PASS	PA
33927 Lane 2	49	99	2023-06-30T16:27:49.211261Z	PASS	5	08297c22-eac9-4857-987f-ec10be4ce121	job	PASS	PA
33927 Lane 2	50	101	2023-06-30T16:27:49.493827Z	PASS	5	08297c22-eac9-4857-987f-ec10be4ce121	job	PASS	PA
33927 Lane 2	51	103	2023-06-30T16:27:49.725299Z	PASS	5	08297c22-eac9-4857-987f-ec10be4ce121	job	PASS	PA
33927 Lane 2	52	105	2023-06-30T16:27:49.965099Z	PASS	5	08297c22-eac9-4857-987f-ec10be4ce121	job	PASS	PA
33927 Lane 2	53	107	2023-06-30T16:27:51.773155Z	PASS	5	08297c22-eac9-4857-987f-ec10be4ce121	job	PASS	PA
33927 Lane 2	54	109	2023-06-30T16:27:52.341495Z	PASS	5	08297c22-eac9-4857-987f-ec10be4ce121	job	PASS	PA

7.4.3 Result archive

Tagsurance 3 system archives the results of 50 previous jobs. The results can be exported as long as the results are in the archive. In addition to the limit of 50 jobs, the archive size is limited to 200M tag results. When one of the constraints is met, the oldest job will be deleted.

JOB ARCHIVE

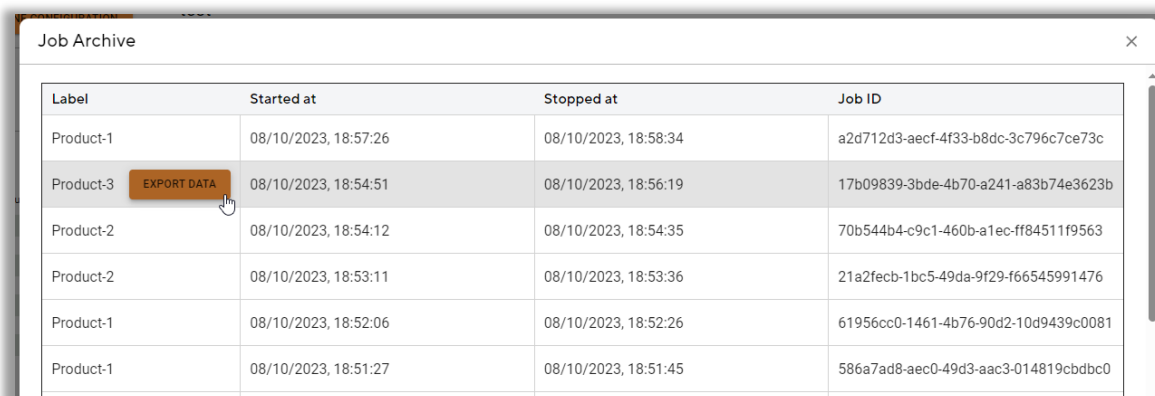

Label	Started at	Stopped at	Job ID
Product-1	08/10/2023, 18:57:26	08/10/2023, 18:58:34	a2d712d3-aecf-4f33-b8dc-3c796c7ce73c
Product-3	08/10/2023, 18:54:51	08/10/2023, 18:56:19	17b09839-3bde-4b70-a241-a83b74e3623b
Product-2	08/10/2023, 18:54:12	08/10/2023, 18:54:35	70b544b4-c9c1-460b-a1ec-ff84511f9563
Product-2	08/10/2023, 18:53:11	08/10/2023, 18:53:36	21a2fecb-1bc5-49da-9f29-f66545991476
Product-1	08/10/2023, 18:52:06	08/10/2023, 18:52:26	61956cc0-1461-4b76-90d2-10d9439c0081
Product-1	08/10/2023, 18:51:27	08/10/2023, 18:51:45	586a7ad8-aec0-49d3-aac3-014819cbdbc0

7.4.4 Error codes

7.4.4.1 Error codes of Read/Write tasks in Tagsurance UHF and Tagsurance SL UHF results

Error code	Description
0 (00 _h)	No error
1 (01 _h)	Tag did not respond to query
2 (02 _h)	Tag did not respond to the command
3 (03 _h)	Tag responds to query, but inventory failed
4 (04 _h)	Tag error: Other error (not covered by the other tag error codes)
52 (34 _h)	Tag error: Memory overrun (too high memory address)
68 (44 _h)	Tag error: Memory locked (memory cannot be read/written)
180 (B4 _h)	Tag error: Insufficient power (carrier level too low)
244 (F4 _h)	Tag error: Non-specific (error-specific codes not supported by the tag)

7.4.4.2 Error codes in Sensitivity test results

Error code	Description
0	No error
1	Out of tolerances
2	Out of range

7.4.4.3 Station result errors

Error	Description
STATION_NOT_TRIGGERED	Tag has past the station before the triggering occurs. Possible reasons: too short <i>distanceFromTrigger</i> for the pattern recognition or the simulated trigger is generated too late
INVALID_TRIGGER_RESPONSE	IO-only device sends both PASS and FAIL signals
MISSING_TRIGGER_RESPONSE	Station do not send PASS/FAIL signal before the next trigger. Possible reasons: IO cable is disconnected, or the lane speed is too high compared to the time required to complete the task list.

7.5 Metrics in operator UI

The system measures and calculates the movement of tags by rotary encoder and trigger sensor. UPH, lane speed, and travelled distance are always shown, whereas the trigger metrics can be shown/hidden by the user.

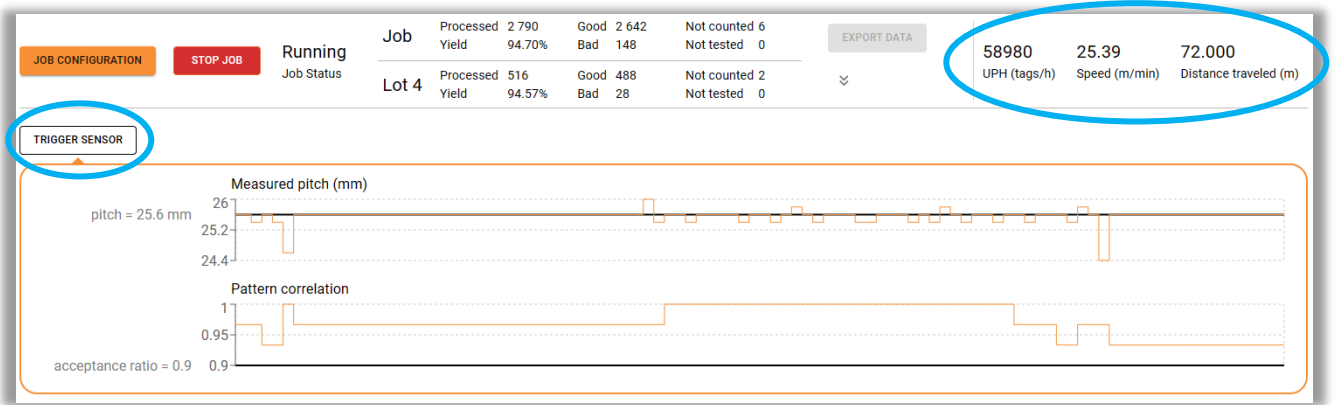

The UPH value is calculated based on the adjustable time window. The default value is 60 seconds, in which case the presented UPH value is extrapolated based on the number of results during the past minute. Since the UPH is a value of speed, tag result types of *PASS*, *FAIL* and *NOT_COUNTED* are taken into account in UPH calculation.

Settings
CANCEL

General
Router

Time window for the Units Per Hour value (in seconds)

60

SAVE

The tag pitch is always measured and shown together with the pitch defined in job configuration. The pattern trigger correlation is shown only if the pattern trigger is defined in the job configuration.

If the correlation between the detected and the expected pattern remains below the acceptance ratio, the tag is not triggered and the measured pitch between triggered tags is multiplied. Non-detected or missing tags are not shown in the results unless the simulated trigger is enabled. The correlations below the acceptance ratio are not shown and for the simulated triggers the correlation is 1.

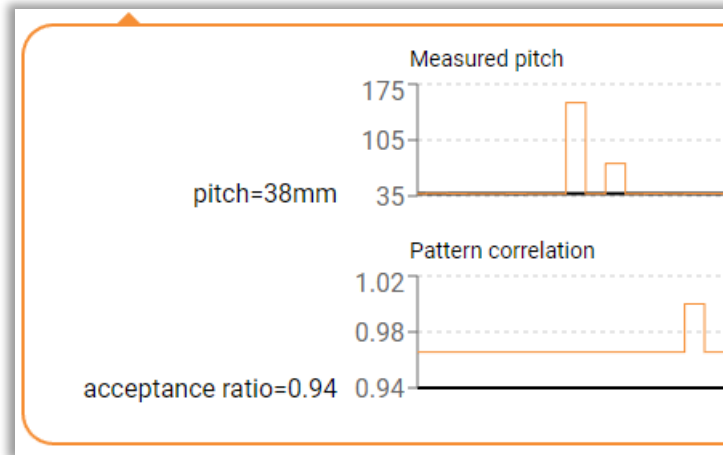

8 Hardware maintenance

The Tagsurance controller and stations should be kept from overheating. The environmental operating temperature should be between +15°C and +35°C (59°F...95°F) for all the components.

The hardware should be kept free of excess dust.

Clean the trigger sensor lenses and rotary encoder wheel from dust and accumulated dirt as needed. Wipe the dust with a brush or wipe with a moist cloth.

Remove accumulated dust from inside Snoop Pro coupling elements (the area seen through the shielding plate opening).

Remove accumulated dust from surfaces of the Tagsurance controller. Remove accumulated dust with a gentle air blow. Remove dust with a brush as needed, and power off the hardware before brushing.

At some point, the O-ring of the rotary encoder wheel is to be replaced. The surface of a measuring wheel is subject to wear. This depends on contact pressure, acceleration behavior in the machine, traversing speed, measurement surface, mechanical alignment of the measuring wheel, temperature, and ambient conditions. We recommend you regularly check the condition of the measuring wheel and replace it as required.

Annual calibration is recommended for Tagsurance UHF, Tagsurance SL UHF, and Tagsurance HF devices measurement devices.

9 Updating the software

9.1 Tagsurance controller

See Section 3.1.1.1 *Updating the software (patching and feature updates)*

9.2 Lane controller firmware

Updating the firmware is automated, no user actions are needed. In case of an error message about incompatible lane controller firmware version at job start, restart Tagsurance controller and let it run for a moment before starting a job.

9.3 Updating Voyantic stations

9.3.1 Tagsurance SL UHF

As updating the firmware is automated, no user actions are needed. In case of an error message about incompatible Tagsurance SL UHF (TSU) firmware version at job start, restart Tagsurance controller and let it run for a moment before starting a job.

9.3.2 Tagsurance HF

Tagsurance HF Update Tool can be found in the Windows servers in folder `C:\Tagsurance 3\Tagsurance HF Update Tool\`.

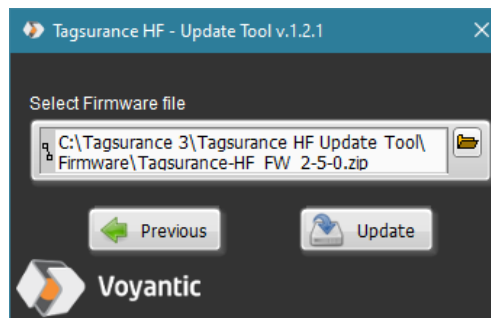

Select the device whose firmware you want to update and browse the firmware file to the control. Tagsurance HF firmware file is a zip file which must not be extracted.

9.3.3 Tagsurance UHF

Use Tagsurance UHF Update Tool, which can be found in Windows servers in folder `C:\Tagsurance 3\Tagsurance UHF Update Tool\`.

- Select only the firmware file and start programming
- The instruction popup will ask you to set the device in programming mode
 - Press down the programming button on the back panel and recycle device power while keeping the button pressed.

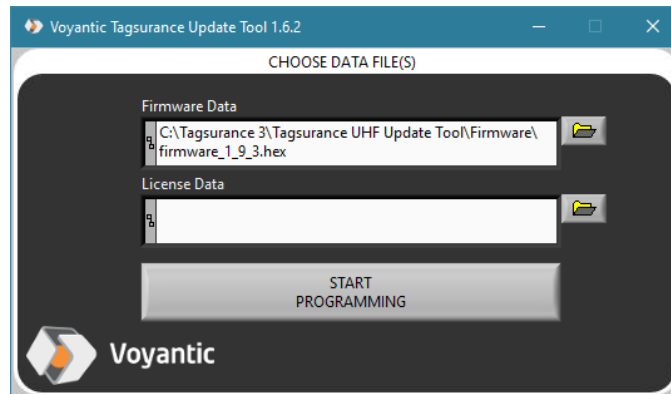

In multiline installations, you can set all the devices in programming mode beforehand, and then run the Update Tool as many times as you have devices. The Update Tool will always update the first device in programming mode it finds.

10 Technical specifications

10.1 Digital IO of lane controller

10.1.1 IO cables

The maximum length of any IO cable connected to a lane controller is 10 m.

10.1.2 Trigger connector

M12, 5-pin connector (female)

PIN number	Description
1	+24 VDC, supply voltage for trigger sensor
2	N.C.
3	GND
4	TRIG
5	N.C.

Logic levels for *TRIG* signal: $V_L = 0.8\text{ V}$, $V_H = 2\text{ V}$

10.1.3 Rotary encoder connector

M12, 8-pin connector (female)

PIN number	Description
1	N.C.
2	Pulse A
3	N.C.
4	Pulse B
5	N.C.
6	N.C.
7	GND
8	+5 VDC, supply voltage for encoder

Logic levels for *Pulse A* and *Pulse B* signals: $V_L = 0.8\text{ V}$, $V_H = 2\text{ V}$

10.1.4 Station connector

In most cases it is highly recommended to use cabling provided by Voyantic. In case other cabling is used with Voyantic stations (Tagsurance SL UHF, etc.), Voyantic may not provide support when problems arise nor any warranty if the hardware is damaged due to non-Voyantic cabling.

For other uses, consult Voyantic support support@voyantic.com with specifications of what is needed and of the station to be connected. This is due to high risk of incorrect assumption of what can be done and how.

Using the station connector to drive the tag puncher, for example, is an exception to the above. For more information, see section 5.2.6 *Puncher*.

Note the 10.1.6 *Output signal current limits*

10.1.4.1 Station connector of Lane Controller 1.x

DE-15 Connector (female), in Lane Controllers with 8 station ports

PIN number	Description
1	+5 VDC
2	GND
3	INPUT A NPN (pass/fail, IO-only:pass)
4	INPUT B NPN (busy/ready, IO-only:fail)
5	INPUT A PNP (pass/fail, IO-only:pass)
6	INPUT B PNP (busy/ready, IO-only:fail)
7	RFU
8	Rotary encoder Pulse B out
9 ... 10	RFU
11	PNP OUT (trigger), active state 24 V
12	NPN OUT (trigger), active state grounded
13	Rotary encoder Pulse A out
14	GND
15	+24 VDC

PNP inputs tolerate voltage levels up to 24 VDC.

The threshold level between active and passive state on the PNP inputs is about 2.4 V.

10.1.4.2 Station connector of Lane Controller 0.3.0

DE-15 Connector (female), in Lane Controllers with 5 station ports

PIN number	Description
1	+5 VDC
2	GND
3	INPUT A, active high (pass/fail, IO-only:pass)
4	INPUT B, active high (busy/ready, IO-only:fail)
5 ... 7	RFU
8	Rotary encoder Pulse B out
9 ... 11	RFU
12	NPN OUT (trigger), active state grounded
13	Rotary encoder Pulse A out
14	GND
15	+24 VDC

The inputs tolerate voltage level up to 24 VDC.

The voltage level on INPUT A and B must be controlled actively, either to low (passive state) or to high (active state).

The threshold level between active and passive state on the INPUTs A and B is about 1.45 V.

10.1.5 Machine IO connector

See the output current limits listed in Section 10.1.6 Output signal current limits.

10.1.5.1 Machine IO connector in Lane controller 1.X

DB-25 Connector (female)

PIN number	Description
1	GND
2	+5 VDC
3	RS232 TxD
4	RS232 RxD
5	Digital input 1 NPN (5/6)
6	Digital input 1 PNP (5/6)
7	Digital input 2 NPN (7/8)
8	Digital input 2 PNP (7/8)
9	Digital input 3 NPN (9/10)
10	Digital input 3 PNP (9/10)
11 ... 12	RFU
13	GND
14	Digital output 1 NPN (14/15)
15	Digital output 1 PNP (14/15)
16	Digital output 2 NPN (16/17)
17	Digital output 2 PNP (16/17)
18	Digital output 3 NPN (18/19)
19	Digital output 3 PNP (18/19)
20	Digital output 4 NPN (20/21)
21	Digital output 4 PNP (20/21)

22	Digital output 5 NPN (22/23)
23	Digital output 5 PNP (22/23)
24	+24 VDC
25	GND

DB-25 machine IO connector has three inputs and five outputs named according to the pin pairs. The inputs and outputs are configured by using these names.

The active state of PNP outputs is 24 V.

PNP inputs tolerate voltage levels up to 24 VDC.

The threshold level between active and passive state on the PNP inputs is about 2.4 V.

10.1.5.2 Machine IO connector in Lane controller 0.3.0

DE-9 connector (female)

PIN number	Description
1	GND
2	Digital output 1 NPN (14/15)
3	Digital output 2 NPN (16/17)
4	Digital output 3 NPN (18/19)
5	GND
6	+5 VDC
7	N.C.
8	N.C.
9	+24 VDC

DE-9 machine IO connector has three digital outputs, which are configured by using the same output names as in DB-25, e.g., “14/15”.

10.1.6 Output signal current limits

Description	Max value
Current at a single NPN output	100 mA
Current from a single PNP output	50 mA
Total current over all PNP outputs and 24 VDC outputs of the lane controller	150 mA

Note: The output current of all station connectors and the machine IO connector are counted in total current limit.

Note: The current of PNP outputs at IO breakouts are powered by 24 VDC of station port output where the IO breakout is connected, and the current is counted in total current limit of lane controller.

10.2 Standard Tagsurance 3 device IO port

DA-15 connector (female)

Devices such as *Tagsurance SL UHF*, *Tagsurance UHF*, and *Tagsurance HF* have this connector.

PIN number	Description
1	N.C.
2	RFU
3	GND
4	GND
5	TRIG -
6	TRIG +
7	Busy/Ready
8	Pass/Fail
9	RFU
10	RFU
11	+5 VDC ¹
12	Logic 0-level reference
13	Logic 1-level reference
14	RFU
15	RFU

1) The maximum output current is 20 mA for Tagsurance SL UHF and Tagsurance HF.

The high and low levels of the output pins 7 and 8 are set by the pins 12 and 13. The voltage level of pin 13 must be higher than the voltage of pin 12.

The trigger signal is a 5-24 V differential signal between pins 5 and 6. If a unipolar signal is preferred, pin 5 can be grounded to either pin 3 or pin 4.

10.3 Digital signals of IO Breakout

10-pin terminal block header (green) MC 1,5/10-GF-3,81

GND	TRIG NPN	TRIG PNP	GND	Busy/Ready NPN	Busy/Ready PNP	GND	Pass/Fail NPN	Pass/Fail PNP	GND
-----	----------	----------	-----	----------------	----------------	-----	---------------	---------------	-----

All signals are outputs.

The active state for PNP outputs is 24 V.

The power for PNP outputs is taken from the lane controller's station port 24 VDC pin, and the current consumption at IO breakout's output must be considered in lane controller's current budget. See *10.1.6 Output signal current limits*.

An example of compatible connectors is the connector with screw terminal "MC 1,5/10-STF-3,8" supplied with the IO breakout.

10.4 Station locations

Requirements for the relative station positions are set to ensure proper operation of all system features.

Minimum distance from trigger to station ¹	Tag pitch or 60 mm, whichever is greater
Minimum distance between stations	50 mm
Minimum distance between the last station and the lot change location ²	50 mm

- 1) The exception is the 0 mm distance from trigger. The 0 mm distance from trigger value sets the system to trigger the station instantly after the lane controller receives a trigger signal. See the use case in Section 5.2.1 Distance from trigger.
- 2) The lot change location must be defined only when the external lot change control is enabled. See the Section 7.3.3.2.

10.5 APIs

10.5.1 REST API

Documentation, versioning and API support life cycle information can be found on the Tagsurance 3 system at:

`https://[system IP address]/api-docs`

In Windows based systems, it is also available locally at: <https://localhost/api-docs>

10.5.2 AsyncAPI

Documentation, versioning and API support life cycle information can be found on the Tagsurance 3 system at:

`https://[system IP address]/async-api-docs`

In Windows based systems, it is also available locally at: <https://localhost/async-api-docs>

10.6 Tagsurance SL UHF

10.6.1 RF performance

See specifications in the Tagsurance 3 Product catalogue.

10.6.2 Protocol parameters

10.6.2.1 ISO 18000-63

Query parameters

Parameter	Value
DR	64/3
M	1 (FM0)
TRext	use pilot tone
Sel	All
Session	S0
Target	A
Q	0

Timing parameters

Parameter	Value
BLF	320 kHz
Tari	12.5 μ s
PW	0.395 * Tari
data-1 length	1.75 * Tari
RTcal	2.75 * Tari
TRcal	DR / BLF

11 Appendix: How to Configure the Pattern Trigger

11.1 What is the Pattern Trigger

Instead of triggering the system every time the trigger sensor is detecting a change between passive and active area, a trigger can be made to only trigger if a predefined pattern of passive and active areas is detected.

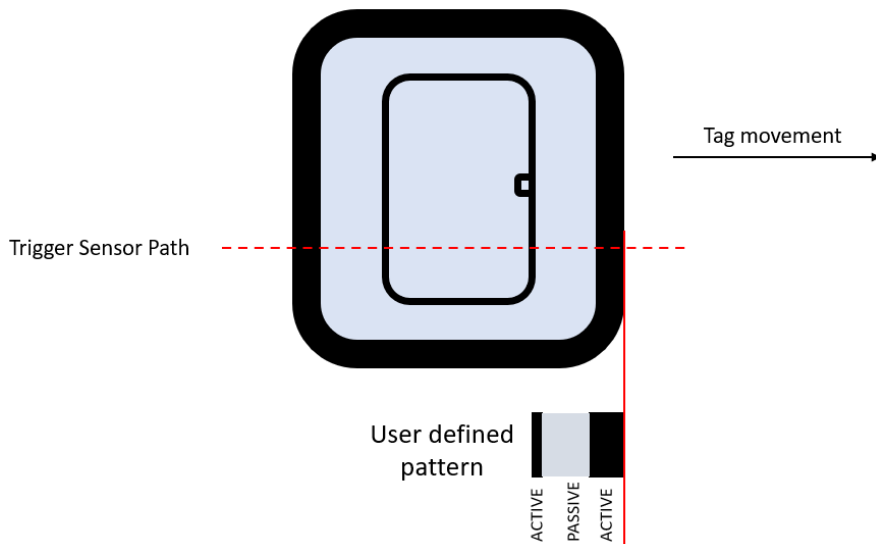
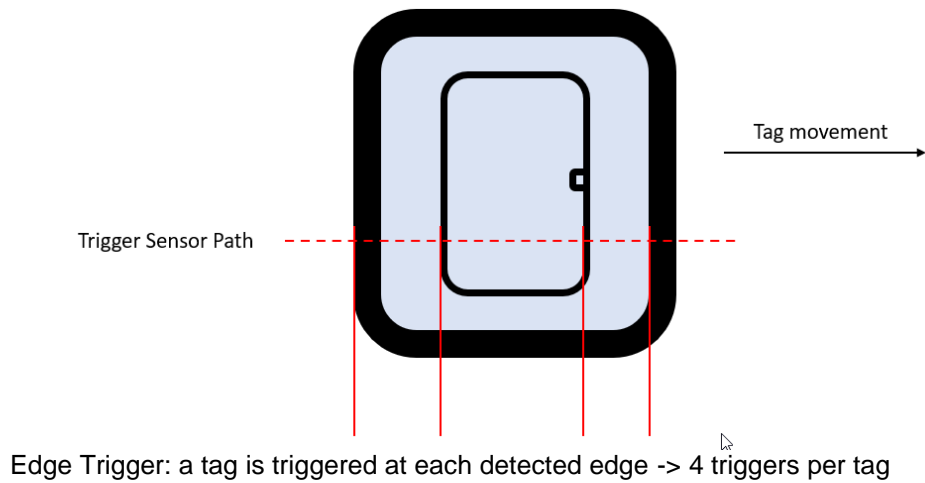

The active and passive areas depend on the trigger sensor settings. In this document the RFID tag's antenna features are expected to be the sensor's active areas as shown in picture above.

11.2 How Pattern Trigger Works

The pattern detection attempts to find the best possible match for the length of the defined *tag pattern* as long as the pattern match ratio stays above the *tag pattern acceptance ratio*. On the other words, as soon as the match ratio increases above the limit, the system keeps recording the positions of match ratios until the match ratio drops below the limit. At that time the location of the best match is determined based on the records and set as trigger location retroactively.

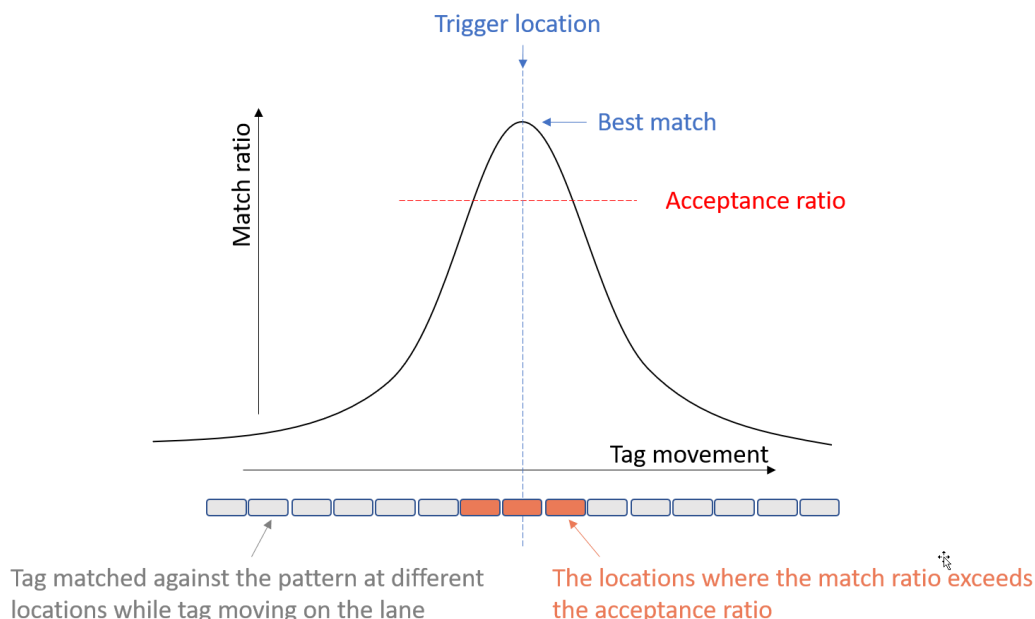

If the acceptance ratio has been set so low that the pattern matches above the criteria all the time, the algorithm cannot define the trigger position. After a valid match, the matching pattern ratio must decrease below the criteria limit before another match is detected.

The matching calculation takes all defined sections into account, not only the active sections. When having a lot of passive area compared to active area in the defined pattern, the matching ratio is high even on top of the empty liner.

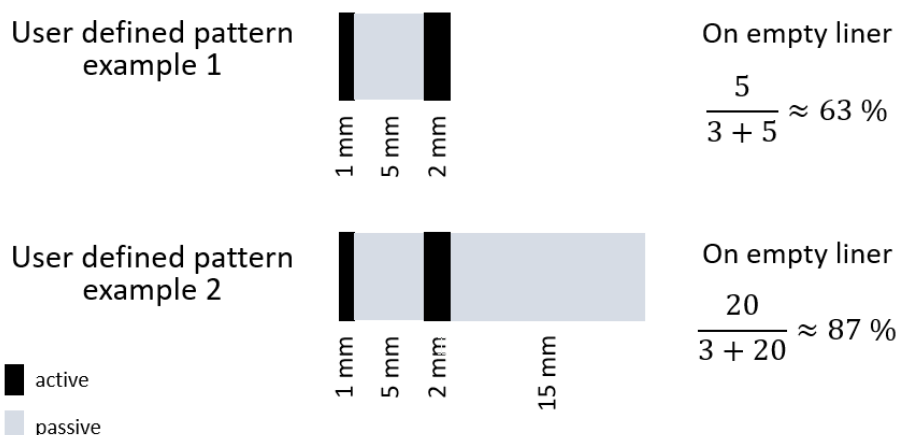

It is important to understand how the passive area in the pattern affects the ratio calculation and use passive areas in a way to help make the pattern unique but no extra.

11.3 Pattern Trigger Configuration

11.3.1 Active and Passive Sections

Configure the trigger settings according to the pattern sections the trigger sensor is detecting.

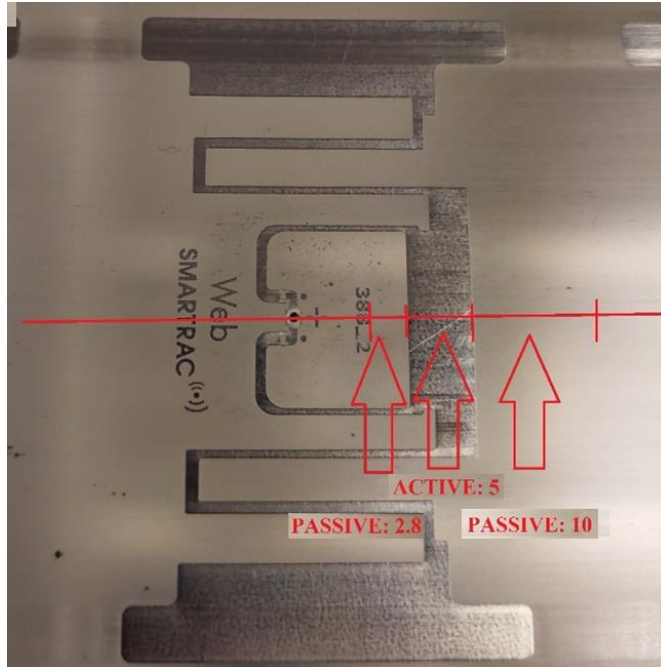

Pattern settings

<input type="button" value="PASSIVE"/>	<input type="button" value="PASSIVE"/>	<input type="button" value="PASSIVE"/>
<input type="button" value="ACTIVE"/>	<input checked="" type="button" value="ACTIVE"/>	<input type="button" value="ACTIVE"/>
<input type="button" value="EITHER"/>	<input type="button" value="EITHER"/>	<input type="button" value="EITHER"/>
<input type="button" value="10 mm"/>	<input type="button" value="5 mm"/>	<input type="button" value="2.8 mm"/>
<input type="button" value="x"/>	<input type="button" value="x"/>	<input type="button" value="x"/>

Trigger offset mm Acceptance ratio

Direction of tag movement ←

Trigger point

-10 0 10

Scale is in millimeters

Pattern Trigger settings in Tagsurance 3 operator UI
 Note: the tag movement is exceptionally from right to left

In case the tag antenna has similar features sequentially, you can make sure the first feature is found correctly by adding a long enough passive section before the first feature of the tag antenna. The first passive section presents a part of the clearance between antennas. However, the passive section must not be any longer what is really needed. The unnecessary long passive section affects the active/passive relation and the pattern detection. Low active/passive relation may cause misdetections. See the Section *11.2 How Pattern Trigger Works*.

11.3.2 Trigger Location Offset

In the example above, the pattern begins with a passive section. By default, the trigger point will be set at the beginning of the pattern. A station, e.g. Tagsurance SL UHF, is triggered when the tag's trigger point reaches the test antenna position on the lane.

With the *trigger location offset* you can move the trigger point past the passive section to the beginning of tag antenna feature. Tagsurance 3 UI shows the trigger point based on the defined offset value. See the figure above.

11.4 Simulated Triggers

Tagsurance 3 system has a feature to create simulated triggers when a tag is not detected because it is missing, or the sensing has failed. The simulated trigger is created after a tag pitch since the previous trigger. It does not matter if the previous trigger is based on a true detected tag or is a simulated one. The simulated trigger is created if the given travel in addition to the pitch is past since the last trigger.

11.4.1 Simulated Trigger with Pattern Trigger

When the simulated trigger is activated, its parameter *simulateTriggerWhenPastPitchMm* must be set long enough to allow the pattern trigger detection to work properly. See the section *11.2 How Pattern Trigger Works*.

The pattern trigger detection creates a trigger retroactively when the match ratio decreases below the acceptance level. That happens later than where the best match is located, so the distance between the best match and the match ratio decreasing under the acceptance level is required to be scanned before the trigger simulation is allowed to happen. This extra travel must be taken into account when defining the simulated trigger's parameter *simulateTriggerWhenPastPitchMm*.

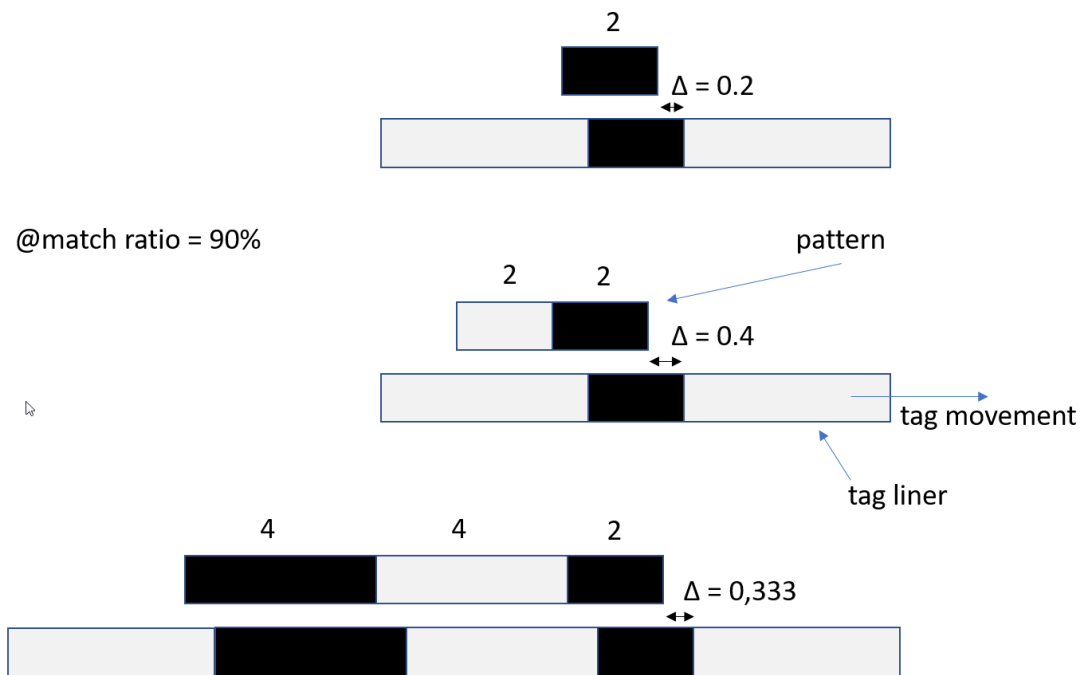

The examples of pattern offsets that reaches the acceptance ratio of 90%

Since the trigger sensor scans the liner at a static location, the entire pattern must travel past the sensor to be detected.

As a summary, the *simulateTriggerWhenPastPitchMm* parameter must be more than the sum of the pattern length and the required offset due to the acceptance ratio decrease. In case of the longest pattern in the picture above, the *simulateTriggerWhenPastPitchMm* must be greater than 10.4 .

In the picture below, the tag is misaligned, and the pitch is longer than expected. The *simulateTriggerWhenPastPitchMm* is set long enough, and the tag can be triggered based on the pattern. A new pitch calculation starts from the pattern-based trigger point.

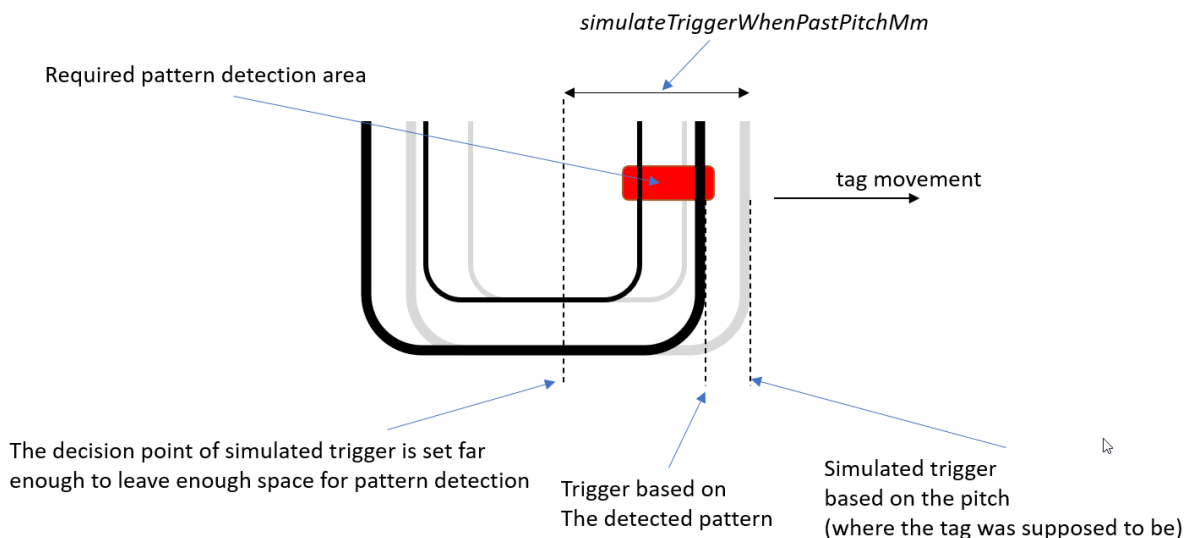

11.5 Hold Off Distance

To prevent unwanted additional triggers, the system trigger can be put on hold after each trigger point for a specified distance. During the hold off distance, the edge and the pattern-based triggers are ignored.

Note: the simulated trigger is the exception here.

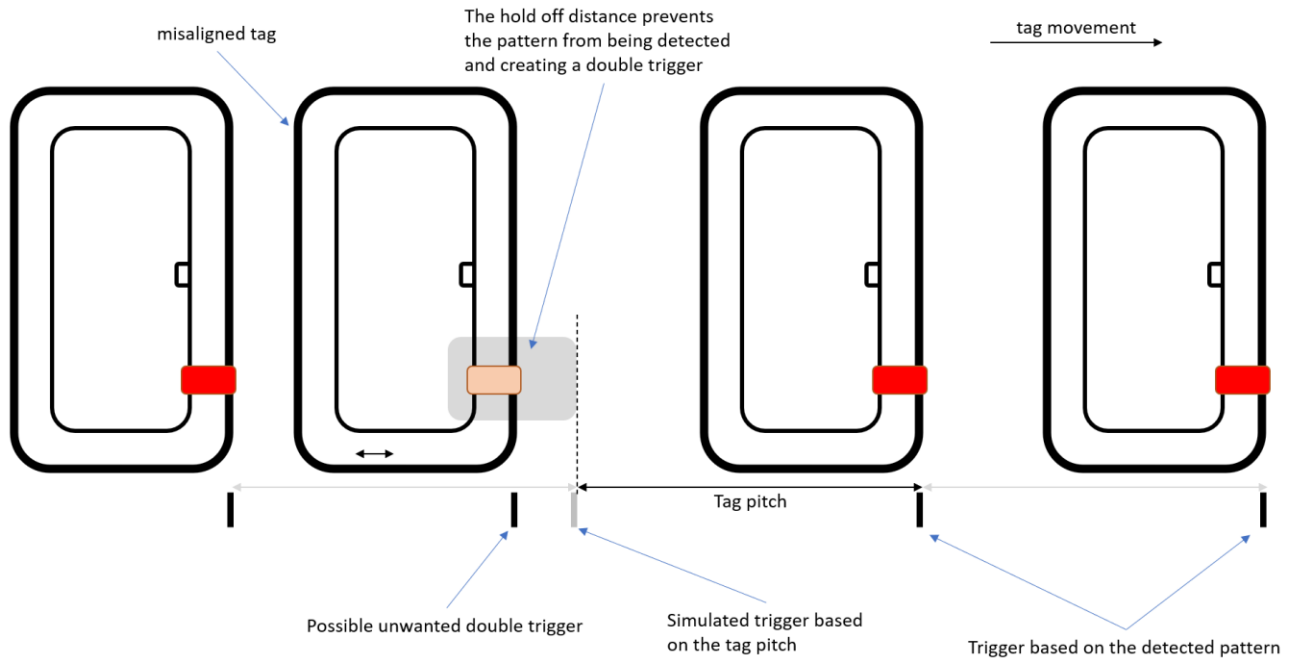

The hold-off distance must be used carefully. Do not use longer hold-off distances than necessary. Especially with simulated trigger, there is a high risk the trigger point may not recover to the correct one after a one missed trigger point.

In the picture below, the simulated trigger is very off where the tag exists, and the hold off distance prevents the trigger placement based on the pattern detection. In this case, the system cannot recover to trigger the tags at correct positions, but triggers are only simulated at wrong positions.

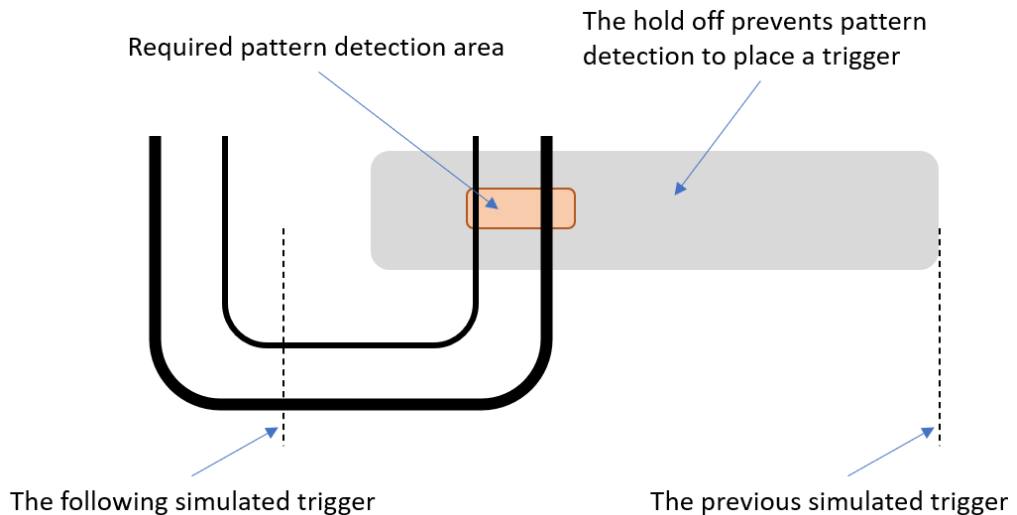

11.6 Summary of Pattern Trigger Configuration

- What are the tag antenna features or trigger mark size the trigger sensor detects on its path.
- Define a unique pattern and use passive areas as much as really needed but no extra.
- Give enough distance for the pattern detection to complete before forcing the simulated trigger (`simulateTriggerWhenPastPitchMm` >> pattern length).
- Make the hold of distance only as long as really needed.
- Consider carefully whether the simulated trigger or the hold of distance are needed.

